

View with pins facing upwards.

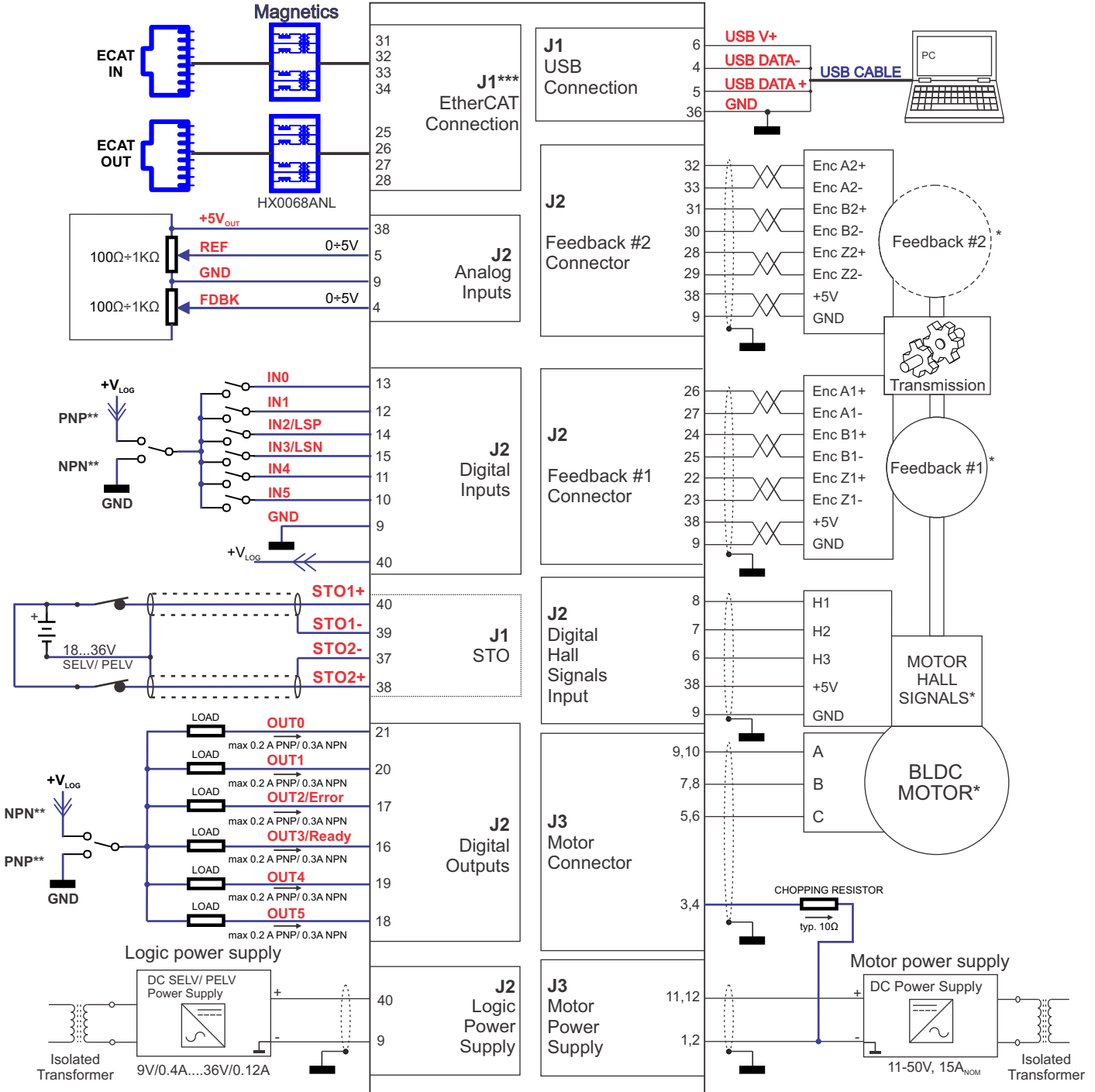

* For all available feedback/ motor options, check the user manual of the drive
 ** The PNP/NPN connection is configured by software
 *** For a detailed ethercat bus connection diagram check the user manual or datasheet of the drive

iPOS4810 MZ-CAT		P/N:P022.015.E122	
iPOS4815 MZ-CAT		P/N:P022.016.E122	
Copyright © Technosoft 2021. All rights reserved.			
iPOS481x MZ-CAT - Electrical Connection Diagram			
Size A4	Document Number: P091.022.MZ.CAT.CDG.0421	Author: ALN	Rev D
Date: 0421	Sheet 1 of 1		