



Terre rare



Rinnovata serie di motori studiati per offrire le potenze specifiche più elevate oggi disponibili sul mercato dei servomotori c.c..

Le elevate competenze aziendali e nuovi strumenti di calcolo computerizzato 3D (software FEA) hanno permesso di realizzare il massimo risultato possibile dall'impiego dei magneti permanenti in Terre Rare.

Questo prodotto riunisce in sé:

- Eccellenti potenze specifiche
- Elevate linearità di rotazione
- Inerzie contenute

This dc permanent magnet motor series has been revised so as to offer the highest specific power available in the market for such motors.

The vast experience that the company has acquired in the dc permanent magnet motor field combined with new design tools such as 3D FEA software, has allowed the optimisation of the performance of the Rare Earth magnets, resulting in:

- *Excellent specific power*
- *Maintained high constant torque*
- *Low inertia*

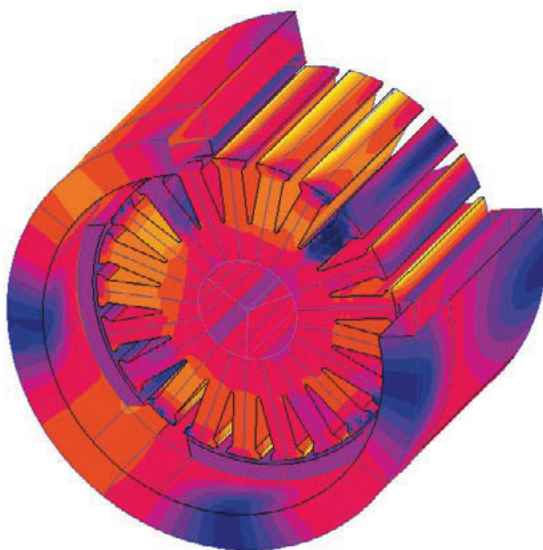

Modello FEA 3D di servomotore a magneti permanenti in Terre Rare che mostra l'andamento dell'induzione magnetica ed il reticolo di calcolo.

3D FEA model of a dc Rare Earth servomotor showing the magnetic induction and the mesh used in the calculations.

SPECIFICHE TECNICHE STANDARD

SPECIFICATIONS OF STANDARD MODELS

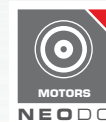

Tipo Servomotori a corrente continua a magneti permanenti

Type *Permanent magnet brushed motors*

Statore A magneti permanenti in Terre rare sinterizzati, incollati e protetti con anello in acciaio INOX

Stator *Rare earth permanent magnets mechanically fastened*

Isolamento Motore e avvolgimento in classe F secondo DIN 0530

Insulation *Motor and winding in class F in accordance with DIN 0530*

Cuscinetti Cuscinetti di alta qualità lubrificati a vita, bloccato anteriormente

Bearings *High quality, life lubricated, front bearing locked*

Raffreddamento Convezione naturale IC0041

Cooling *Natural convection IC0041*

Grado di Protezione IP44

Level of Protection *IP44*

Opzioni disponibili

Available options

Trasduttore di Posizione Encoder incrementale risoluzione a richiesta

Position sensor *Incremental encoder*

Freno di sicurezza Coppia frenante > Coppia nominale motore

Safety brake *Holding torque > Rated torque of the electric motor*

Alimentazione Cavo uscente su pressacavo, connettore tipo elettrovalvola IP55

Power supply *Cable, IP55 connector*

Grado di Protezione IP 55

Level of Protection *IP55*



Serie N17

N17 Series

CARATTERISTICHE GENERALI - GENERAL CHARACTERISTICS

Tipo <i>Type</i>		N17L	
Tensione Nominale <i>Rated Voltage</i>	V	24	24
Velocità Nominale <i>Rated Speed</i>	Rpm	2025	4000
Potenza Nominale <i>Rated Power</i>	W	23	38
Codice di Avvolgimento <i>Winding Code</i>		839	823

CARATTERISTICHE TECNICHE - TECHNICAL CHARACTERISTICS

Coppia Continuativa di Stallo (*) <i>Continuous Stall Current (*)</i>	Nm	0,12	0,11
Corrente Continuativa di Stallo (*) <i>Continuous Stall Torque (*)</i>	A	1,90	2,70
Coppia Nominale (*) <i>Rated Torque (*)</i>	Nm	0,11	0,09
Corrente Nominale (*) <i>Rated Current (*)</i>	A	1,70	2,60
Coppia di Picco allo Spunto <i>Start Peak Torque</i>	Nm	0,36	0,33
Corrente di Picco <i>Start Peak Torque</i>	A	5,70	8,10
Resistenza Totale <i>Total Resistance</i>	Ω	5,10	2,18
Induttanza <i>Inductance</i>	mH	2,50	0,85
Costante di Coppia <i>Torque Constant</i>	Nm/A	0,06	0,04
Costante di Tensione <i>Voltage Constant</i>	V/10 ³ Rpm	7,15	4,40
Costante di Tempo Elettrica <i>Electrical Time Constant</i>	ms	0,49	0,39
Costante di Tempo Termica <i>Thermal Time Constant</i>	min	21	16

DATI MECCANICI - MECHANICAL DATA

Momento di Inerzia <i>Moment of Inertia</i>	Kg·m ²	3,2E-06	
Massa <i>Mass</i>	Kg	0,58	
Massimo Carico Radiale <i>Maximum Radial Load</i>	N	90	
Massimo Carico Assiale <i>Maximum Axial Load</i>	N	50	

CARATTERISTICHE TERMICHE - THERMAL CHARACTERISTICS

Temperatura di Funzionamento <i>Rated Temperature</i>	°C	0 ÷ 40 °C	
Classe di Isolamento <i>Type of Insulation</i>		F	
Grado di Protezione <i>Level of Protection</i>		IP44	
Montaggio <i>Mounting</i>		Flangiato - Flanged (**)	

(*) Dati rilevati a temperatura ambiente di 25°C e con temperatura massima del collettore pari a 115 °C.
 (*) The data was obtained at a room temperature of 25 °C with 115 °C on the commutator.

(**) Flangia in acciaio 150x150x8 mm
 (***) Steel flange 150x150x8 mm

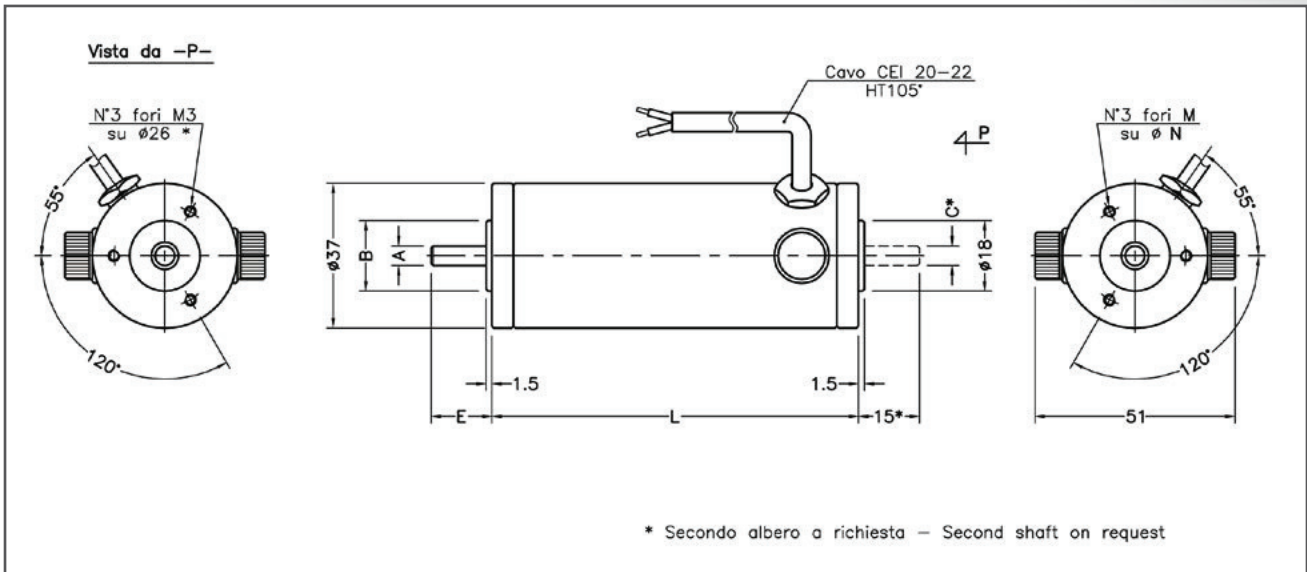

Tolleranze sulle dimensioni angolari : $\pm 5^\circ$
 The tolerance on angular dimensions: $\pm 5^\circ$

Optionals

Optionals

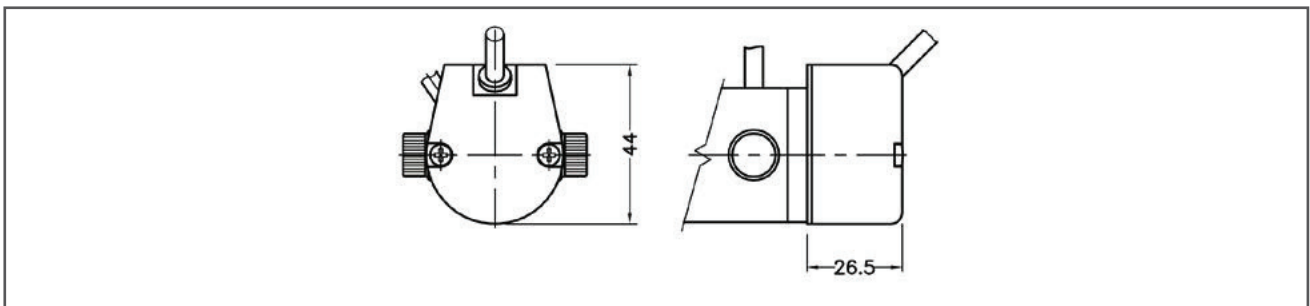

DIMENSIONI - DIMENSIONS

Taglia Size	Tipo di Flangia Flange type	A ^{h6}	B ^{h7}	C ^{h6}	E ± 0.2	L ± 0.5	M	N
N17L	Standard	5	18	6	15	93,5	M3	26



Caratteristiche Coppia-Velocità

Torque-Speed characteristics

N17L 839

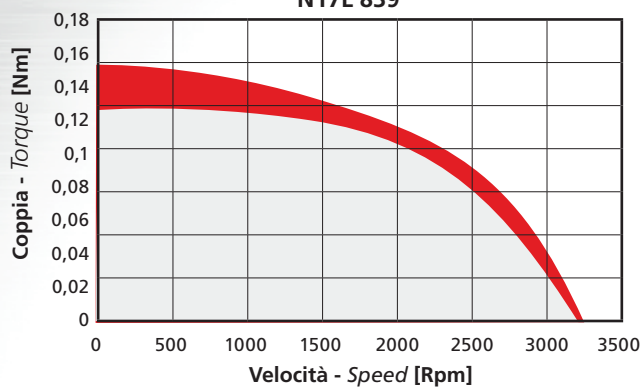

N17L 823

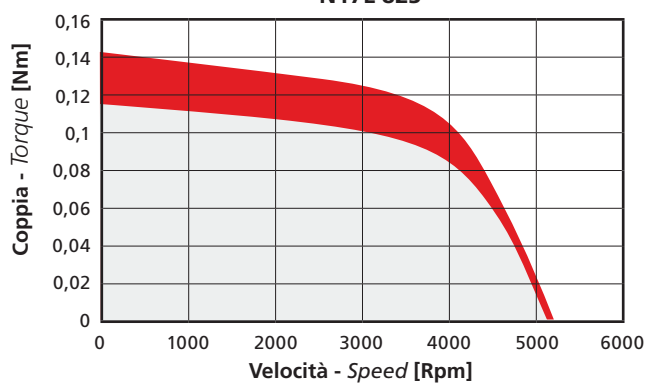

□ S1

■ S2, 30 min.

CARATTERISTICHE GENERALI - GENERAL CHARACTERISTICS

Tipo Type		N45C	N45M				N45ML	
Tensione Nominale Rated Voltage	V	24	24	32	48	75	24	48
Velocità Nominale Rated Speed	Rpm	3060	2750	3010	3260	3100	2700	3080
Potenza Nominale Rated Power	W	77	115	126	137	136	164	184
Codice di Avvolgimento Winding Code		984	970	980	630	105	697	691

CARATTERISTICHE TECNICHE - TECHNICAL CHARACTERISTICS

Coppia Continuativa di Stallo (*) Continuous Stall Current (*)	Nm	0,26	0,44	0,44	0,45	0,45	0,64	0,65
Corrente Continuativa di Stallo (*) Continuous Stall Torque (*)	A	4,65	6,20	5,20	3,70	2,30	8,40	5,00
Coppia Nominale (*) Rated Torque(*)	Nm	0,24	0,40	0,40	0,40	0,42	0,58	0,57
Corrente Nominale (*) Rated Current (*)	A	4,50	6,10	5,10	3,45	2,20	8,15	4,65
Coppia di Picco allo Spunto Start Peak Torque	Nm	0,78	1,32	1,32	1,35	1,35	1,92	1,95
Corrente di Picco Start Peak Torque	A	13,95	18,60	15,60	11,10	6,90	25,20	15,00
Resistenza Totale Total Resistance	Ω	1,11	0,57	0,85	1,56	3,70	0,43	1,05
Induttanza Inductance	mH	0,50	0,30	0,47	1,00	2,50	0,21	0,67
Costante di Coppia Torque Constant	Nm/A	0,06	0,07	0,08	0,12	0,20	0,08	0,13
Costante di Tensione Voltage Constant	V/10 ³ Rpm	6,16	7,45	9,23	13,10	21,10	7,80	13,85
Costante di Tempo Elettrica Electrical Time Constant	ms	0,45	0,53	0,55	0,64	0,68	0,49	0,64
Costante di Tempo Termica Thermal Time Constant	min	20	21	21	19	20	23	18

DATI MECCANICI - MECHANICAL DATA

Momento di Inerzia Moment of Inertia	Kg·m ²	2,1E-5	4,0E-5				5,4E-5	
Massa Mass	Kg	0,76	1,15				1,48	
Massimo Carico Radiale Maximum Radial Load	N	100	200				200	
Massimo Carico Assiale Maximum Axial Load	N	40	70				70	

CARATTERISTICHE TERMICHE - THERMAL CHARACTERISTICS

Temperatura di Funzionamento Rated Temperature	°C	0 ÷ 40 °C						
Classe di Isolamento Type of Insulation		F						
Grado di Protezione Level of Protection		IP44						
Montaggio Mounting		Flangiato - Flanged (**)						

(*) Dati rilevati a temperatura ambiente di 25°C e con temperatura massima del collettore pari a 115 °C.
 (*) The data was obtained at a room temperature of 25 °C with 115 °C on the commutator.

(**) Flangia in acciaio 150x150x8 mm
 (***) Steel flange 150x150x8 mm

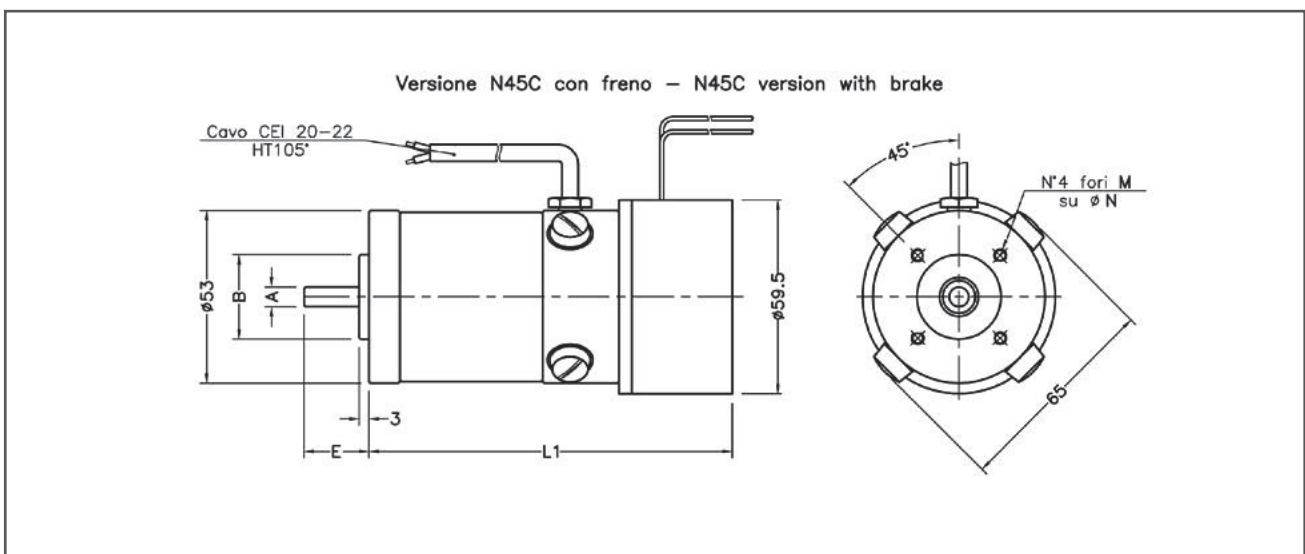
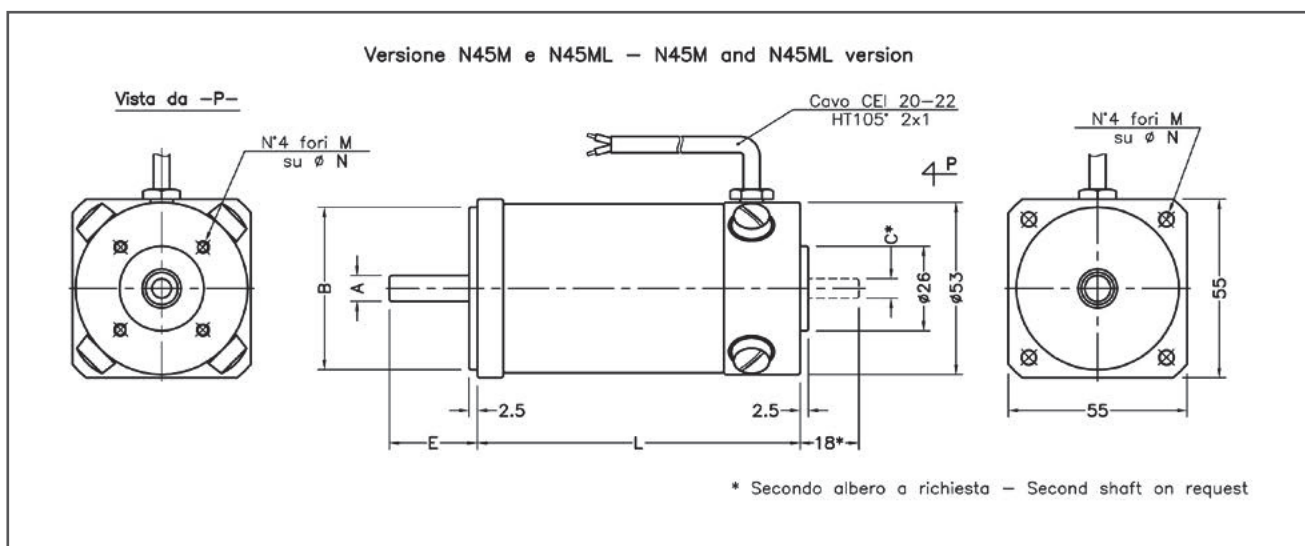
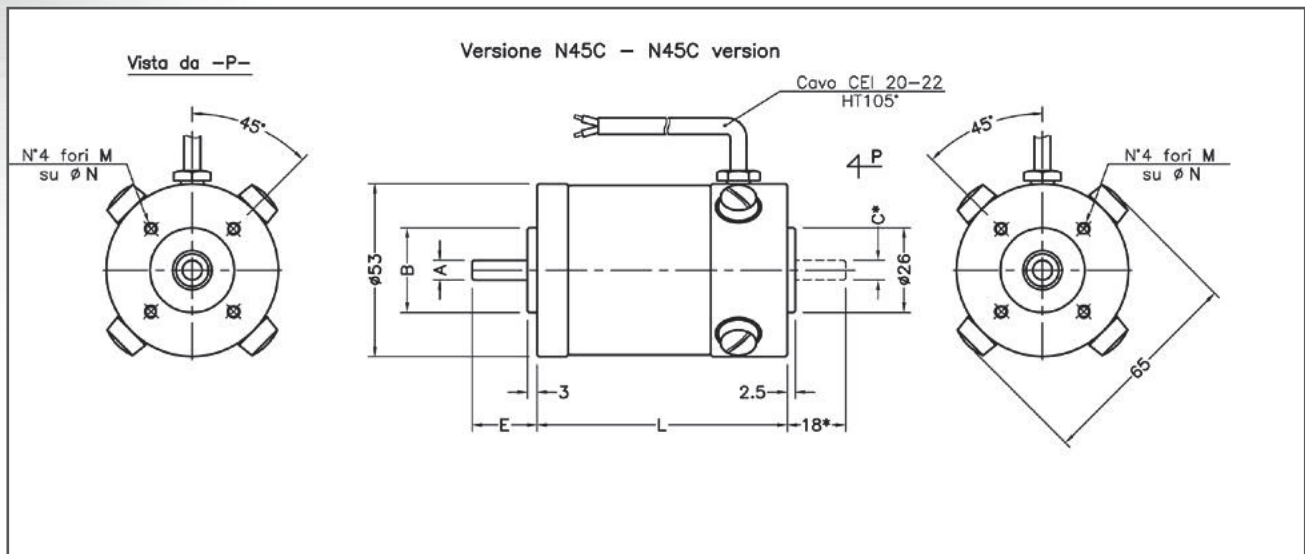

Tolleranze sulle dimensioni angolari : $\pm 5^\circ$
 The tolerance on angular dimensions: $\pm 5^\circ$

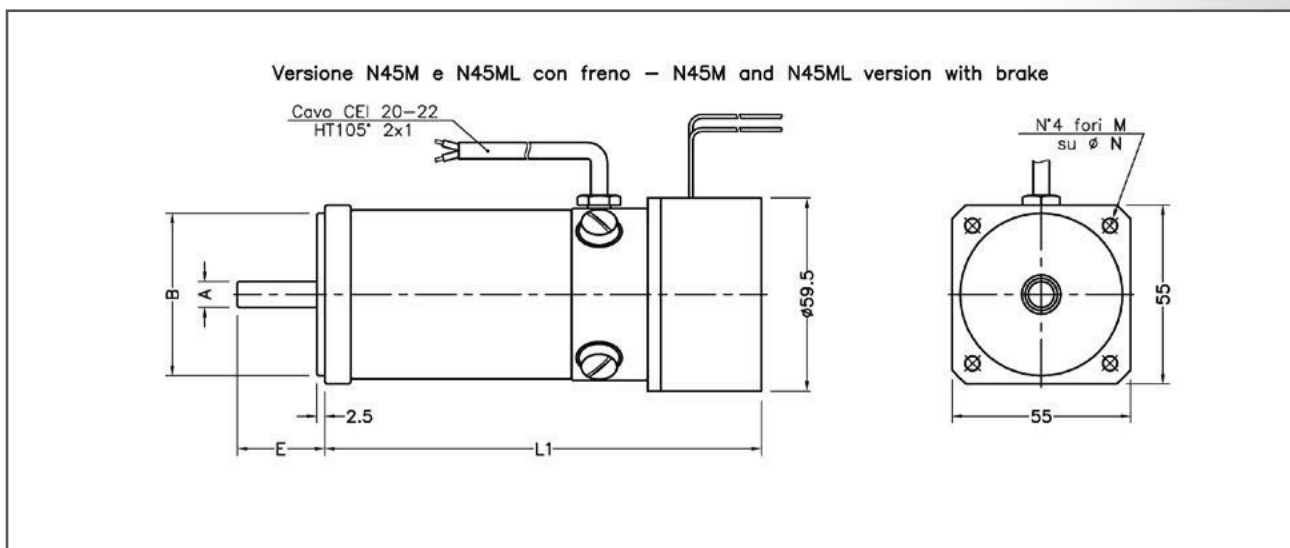

Optionals

Optionals

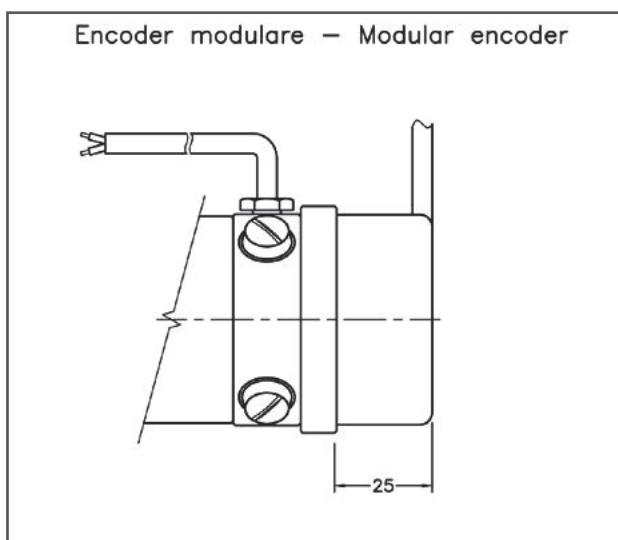

DIMENSIONI - DIMENSIONS

Taglia Size	Tipo di Flangia Flange type	A ^{h6}	B ^{h7}	C ^{h6}	E ^{±0,2}	L ^{±0,5}	L1 ^{±0,5}	M	N
N45C	Standard	6	25	6	20	77	112	M4	36
N45M	Standard	8	50	6	27	99,5	134,5	4,5	60
N45ML	Standard	8	50	6	27	123,5	158,5	4,5	60



Caratteristiche Coppia-Velocità

Torque-Speed characteristics

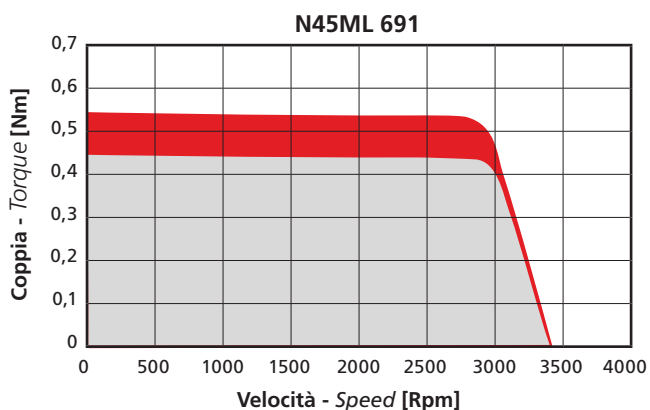
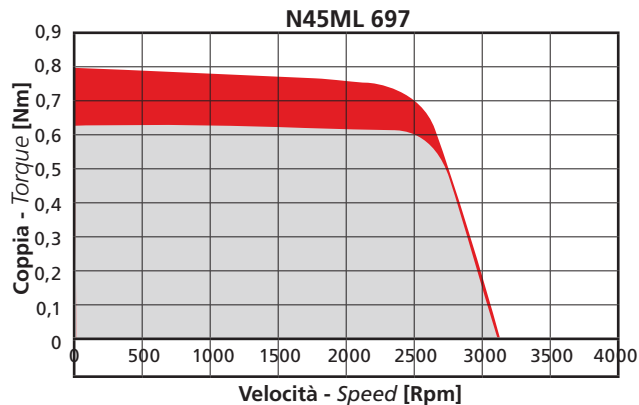
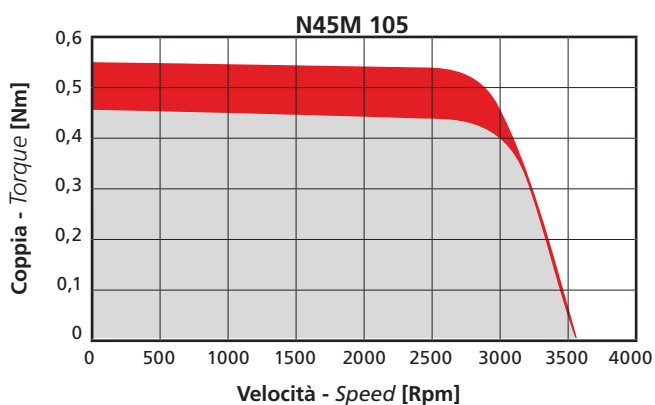
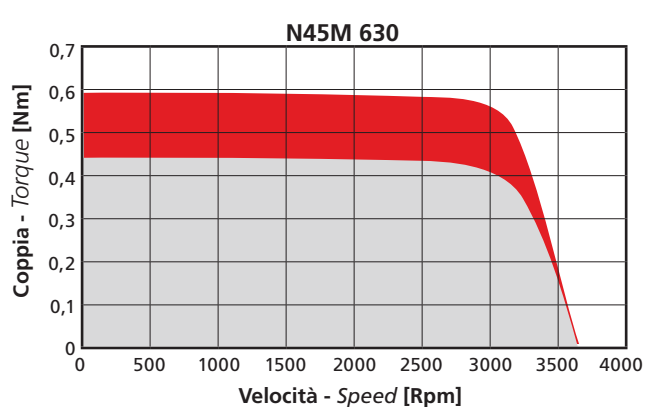
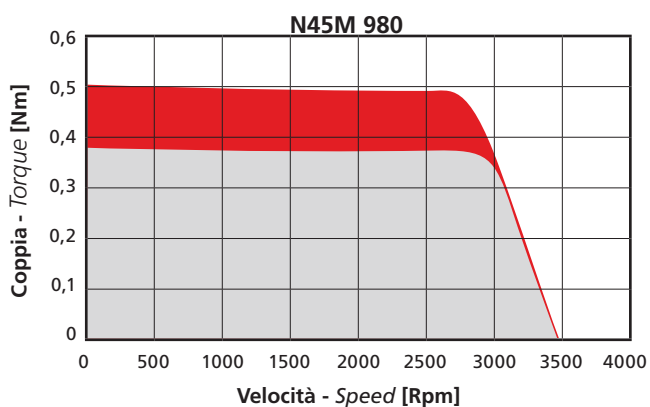
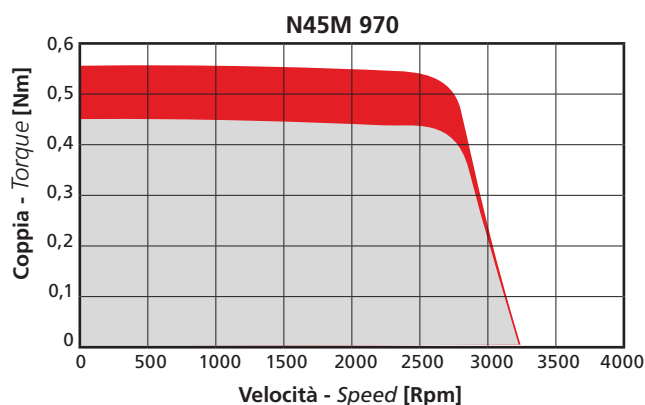
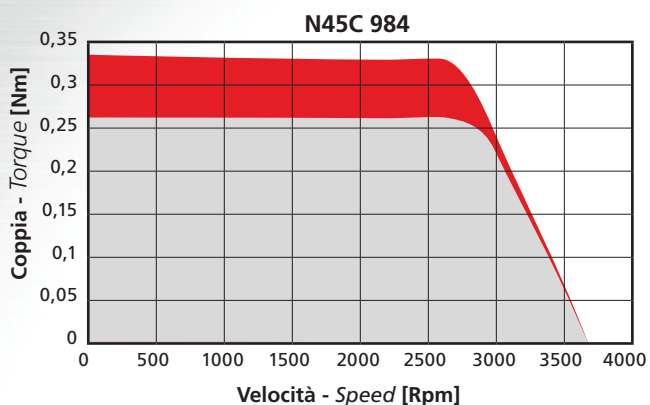

■ S1

■ S2, 30 min.

CARATTERISTICHE GENERALI - GENERAL CHARACTERISTICS

Tipo Type		N70C				N70M	
Tensione Nominale Rated Voltage	V	24	24	42	48	48	90
Velocità Nominale Rated Speed	Rpm	1900	3150	2900	2200	2800	3200
Potenza Nominale Rated Power	W	185	247	237	184	408	442
Codice di Avvolgimento Winding Code		723	724	714	721	771	775

CARATTERISTICHE TECNICHE - TECHNICAL CHARACTERISTICS

Coppia Continuativa di Stallo (*) Continuous Stall Current (*)	Nm	1,03	0,93	0,95	1,00	1,90	1,90
Corrente Continuativa di Stallo (*) Continuous Stall Torque (*)	A	10,00	14,50	7,20	5,50	12,60	7,30
Coppia Nominale (*) Rated Torque(*)	Nm	0,93	0,75	0,78	0,80	1,39	1,32
Corrente Nominale (*) Rated Current (*)	A	9,40	12,50	6,40	4,65	9,50	5,50
Coppia di Picco allo Spunto Start Peak Torque	Nm	3,09	2,79	2,85	3,00	5,70	5,70
Corrente di Picco Start Peak Torque	A	30,00	43,50	21,60	16,50	37,80	21,90
Resistenza Totale Total Resistance	Ω	0,38	0,29	0,48	0,91	0,39	0,95
Induttanza Inductance	mH	0,35	0,14	0,55	1,05	0,34	0,90
Costante di Coppia Torque Constant	Nm/A	0,10	0,06	0,13	0,18	0,15	0,26
Costante di Tensione Voltage Constant	V/10 ³ Rpm	11,06	6,90	13,80	19,90	16,65	27,70
Costante di Tempo Elettrica Electrical Time Constant	ms	0,92	0,48	1,15	1,15	0,87	0,95
Costante di Tempo Termica Thermal Time Constant	min	35	25	26	25	37	44

DATI MECCANICI - MECHANICAL DATA

Momento di Inerzia Moment of Inertia	Kg·m ²	1,6E-4				3,3E-4	
Massa Mass	Kg	2,3				3,6	
Massimo Carico Radiale Maximum Radial Load	N	300				330	
Massimo Carico Assiale Maximum Axial Load	N	80				80	

CARATTERISTICHE TERMICHE - THERMAL CHARACTERISTICS

Temperatura di Funzionamento Rated Temperature	°C	0 ÷ 40 °C					
Classe di Isolamento Type of Insulation		F					
Grado di Protezione Level of Protection		IP44					
Montaggio Mounting		Flangiato - Flanged (**)					

(*) Dati rilevati a temperatura ambiente di 25°C e con temperatura massima del collettore pari a 115 °C.
 (*) The data was obtained at a room temperature of 25 °C with 115 °C on the commutator.

(**) Flangia in acciaio 150x150x8 mm
 (***) Steel flange 150x150x8 mm

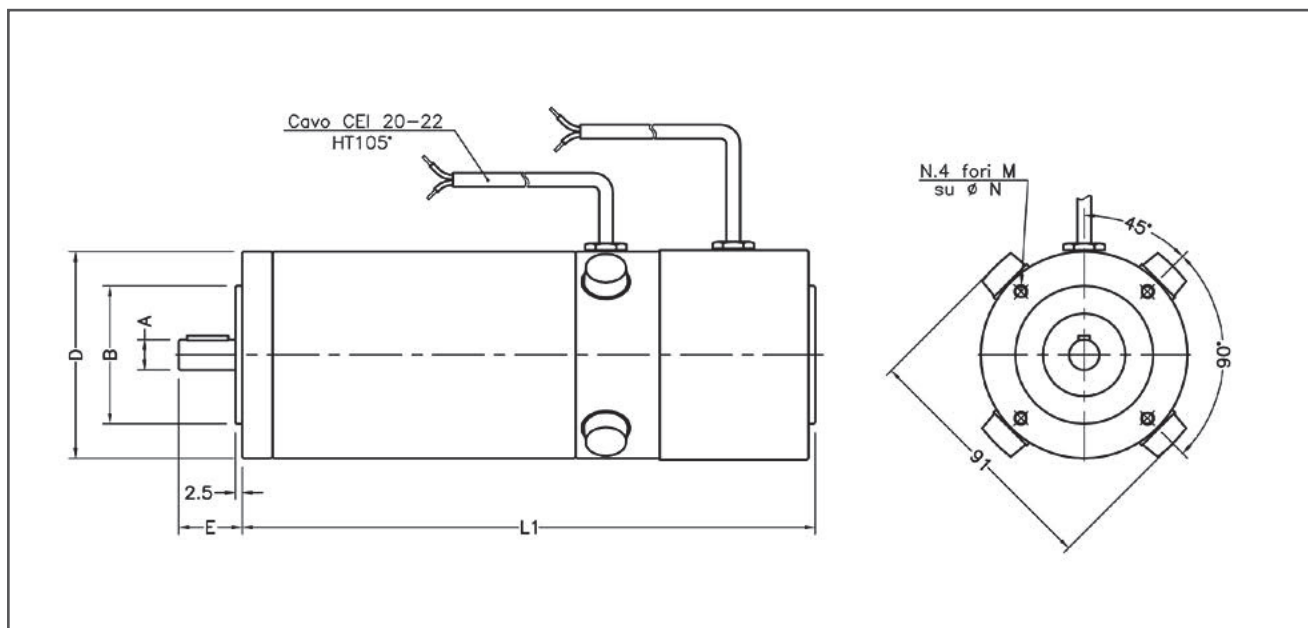
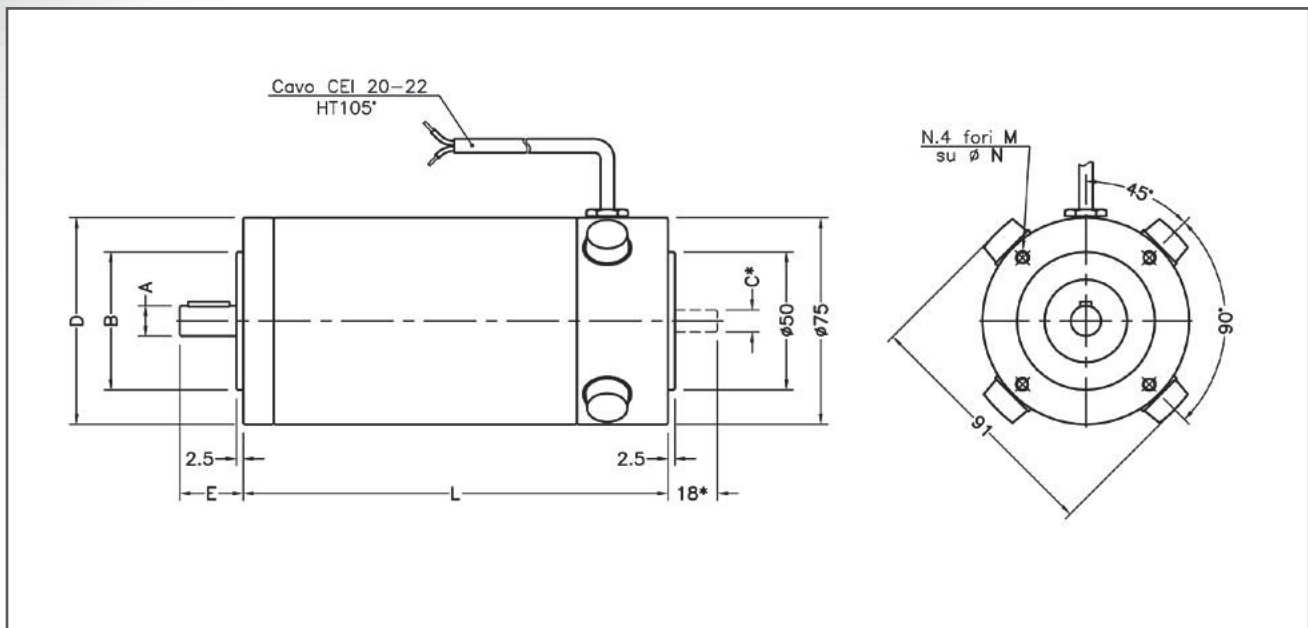

Tolleranze sulle dimensioni angolari : $\pm 5^\circ$
 The tolerance on angular dimensions: $\pm 5^\circ$

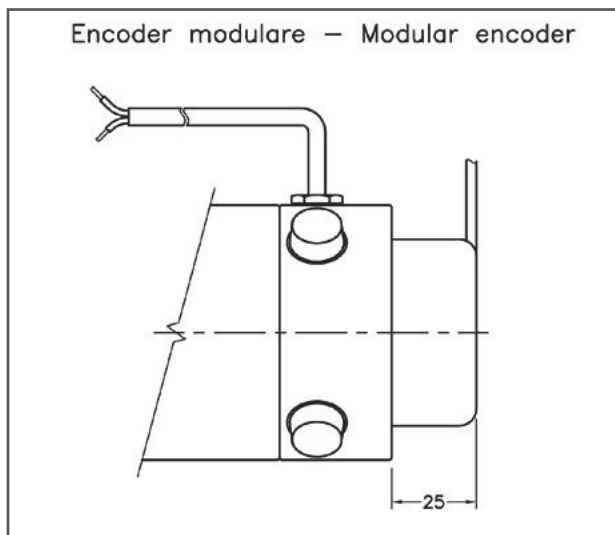

DIMENSIONI - DIMENSIONS

Taglia Size	Tipo di Flangia Flange type	A ^{h6}	B ^{h7}	C ^{h6}	D	E ^{±0,2}	L ^{±0,5}	L1 ^{±0,5}	M	N	Linguetta Key
N70C	56B14	11	50	8	75	23	114	166	M5	65	4x4x15
	63B14	14	60	8	90	30				75	5x5x20
N70M	56B14	11	50	8	75	23	154	206	M5	65	4x4x15
	63B14	14	60	8	90	30				75	5x5x20



Caratteristiche Coppia-Velocità

Torque-Speed characteristics

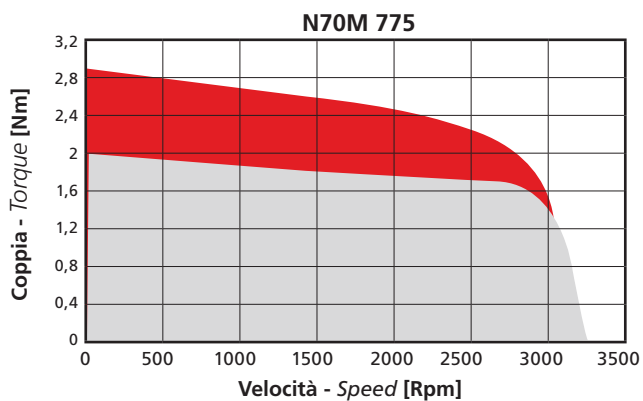
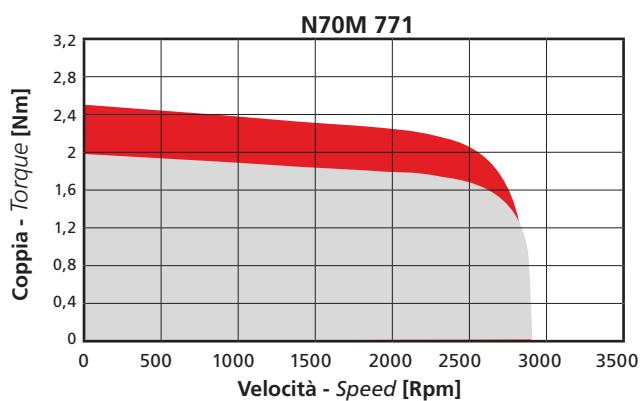
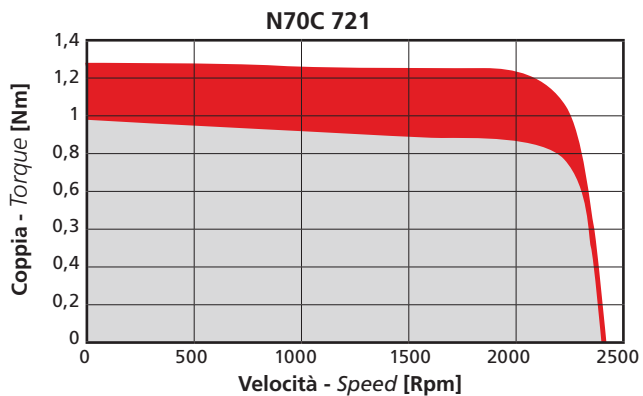
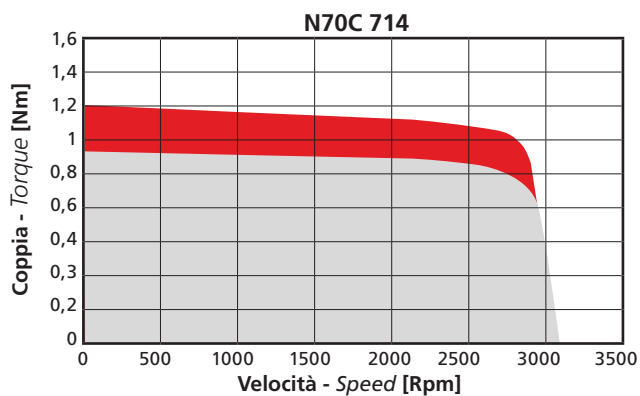
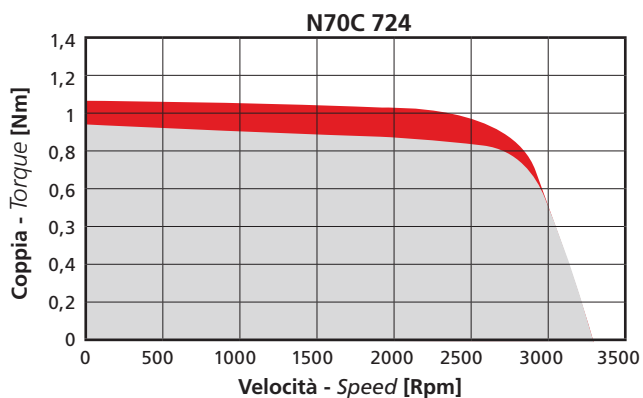
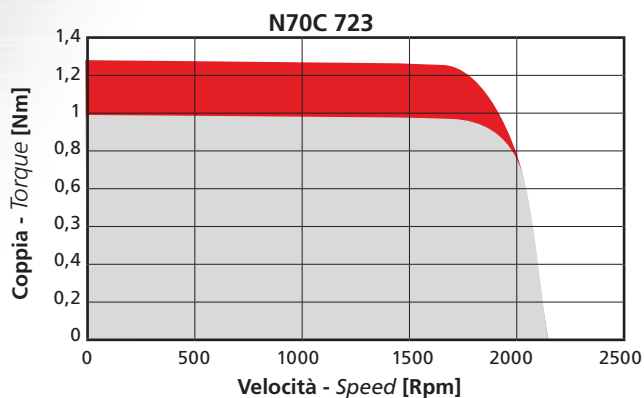

■ S1

■ S2, 30 min.

CARATTERISTICHE GENERALI - GENERAL CHARACTERISTICS

Tipo Type		N100C			N100M		
Tensione Nominale Rated Voltage	V	48	65	90	90		
Velocità Nominale Rated Speed	Rpm	3150	2900	2900	3000		
Potenza Nominale Rated Power	W	571	538	568	861		
Codice di Avvolgimento Winding Code		722	719	715	726		

CARATTERISTICHE TECNICHE - TECHNICAL CHARACTERISTICS

Coppia Continuativa di Stallo (*) Continuous Stall Current (*)	Nm	2,05	2,05	2,05	4,01		
Corrente Continuativa di Stallo (*) Continuous Stall Torque (*)	A	15,2	10,4	8,0	14,6		
Coppia Nominale (*) Rated Torque (*)	Nm	1,73	1,77	1,87	2,74		
Corrente Nominale (*) Rated Current (*)	A	13,5	9,4	7,3	10,7		
Coppia di Picco allo Spunto Start Peak Torque	Nm	6,15	6,15	6,15	12,03		
Corrente di Picco Start Peak Torque	A	45,6	31,2	24	43,8		
Resistenza Totale Total Resistance	Ω	0,37	0,50	0,72	0,36		
Induttanza Inductance	mH	0,38	0,82	1,48	0,56		
Costante di Coppia Torque Constant	Nm/A	0,135	0,197	0,256	0,275		
Costante di Tensione Voltage Constant	V/10 ³ Rpm	14,60	21,00	29	28,90		
Costante di Tempo Elettrica Electrical Time Constant	ms	1,0	1,6	2,1	1,6		
Costante di Tempo Termica Thermal Time Constant	min	32	19	20	28		

DATI MECCANICI - MECHANICAL DATA

Momento di Inerzia Moment of Inertia	Kg·m ²	8,7E-4			1,8E-3		
Massa Mass	Kg	4,5			6,5		
Massimo Carico Radiale Maximum Radial Load	N	380			450		
Massimo Carico Assiale Maximum Axial Load	N	100			100		

CARATTERISTICHE TERMICHE - THERMAL CHARACTERISTICS

Temperatura di Funzionamento Rated Temperature	°C	0 ÷ 40 °C					
Classe di Isolamento Type of Insulation		F					
Grado di Protezione Level of Protection		IP44					
Montaggio Mounting		Flangiato - Flanged (**)					

(*) Dati rilevati a temperatura ambiente di 25°C e con temperatura massima del collettore pari a 115 °C.
 (*) The data was obtained at a room temperature of 25 °C with 115 °C on the commutator.

(**) Flangia in acciaio 150x150x8 mm
 (***) Steel flange 150x150x8 mm

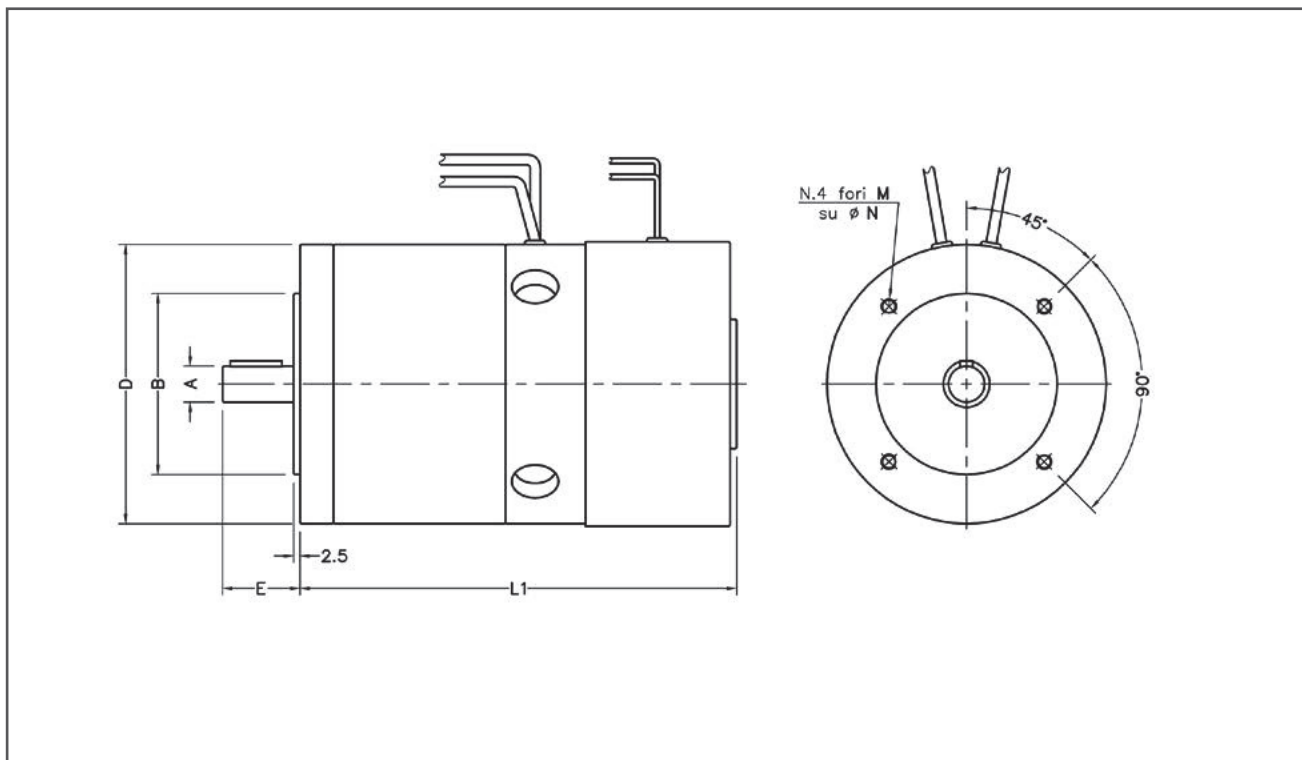
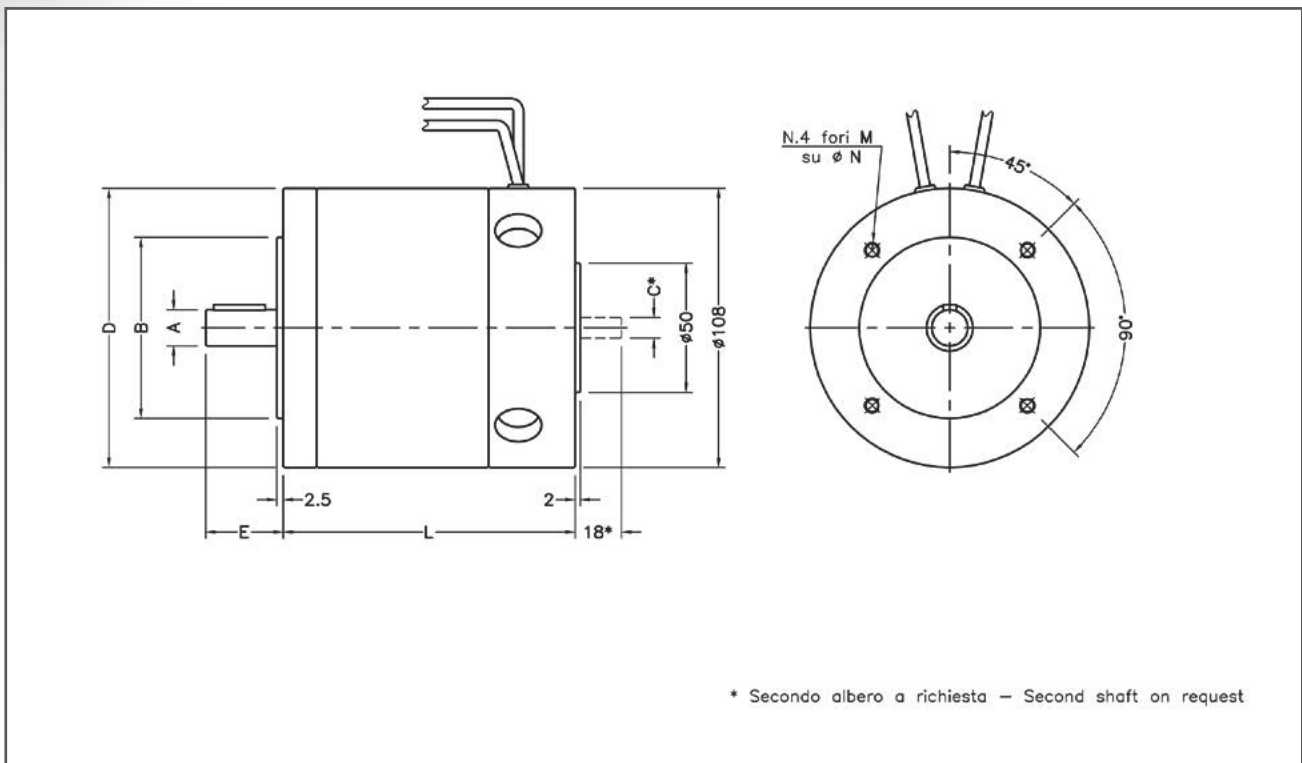

Tolleranze sulle dimensioni angolari : $\pm 5^\circ$
 The tolerance on angular dimensions: $\pm 5^\circ$

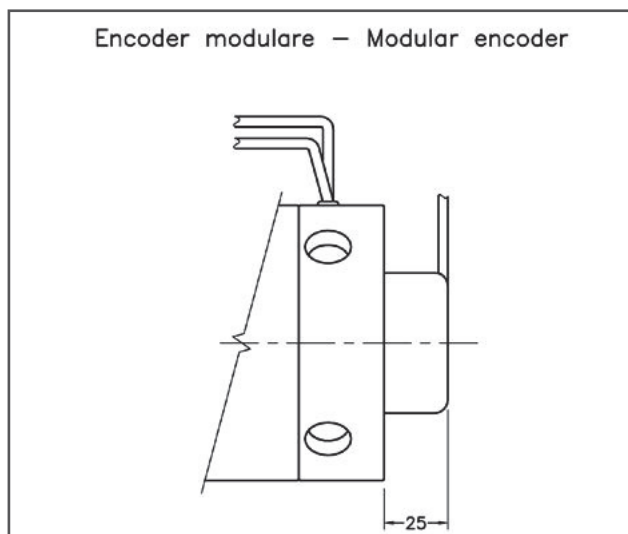

DIMENSIONI - DIMENSIONS

Taglia Size	Tipo di Flangia Flange type	A ^{b6}	B ^{b7}	C ^{b6}	D	E ^{±0.2}	L ^{±0.5}	L1 ^{±0.5}	M	N	Linguetta Key
N100C	63B14	14	60	8	108	30	116	169	M5	75	5x5x20
	71B14		70						M6	85	
	63B5		95						M8(1)	115	
	71B5		110						∅9	130	
N100M	63B14	14	60	8	108	30	149	202	M5	75	5x5x20
	71B14		70						M6	85	
	63B5		95						M8(1)	115	
	71B5		110						∅9	130	

(1) A causa di interferenza fra viti e corpo motore non è possibile praticare i fori passanti come da normativa UNEL-MEC
 (1) Threaded holes instead of through holes due to interference between the screws and the motor body

(2) Flangia di forma quadrata 120x120 mm
 (2) Square flange 120x120 mm



Caratteristiche Coppia-Velocità

Torque-Speed characteristics

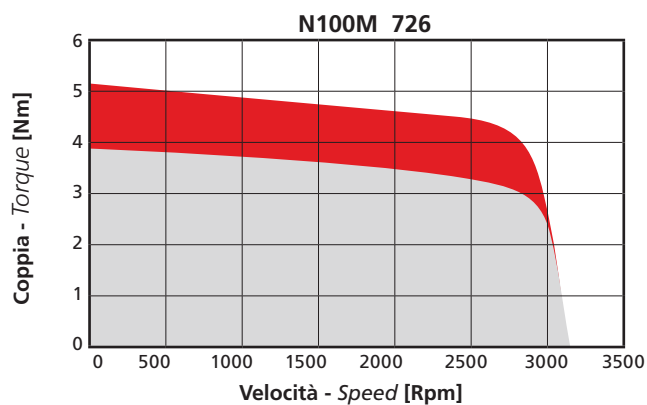
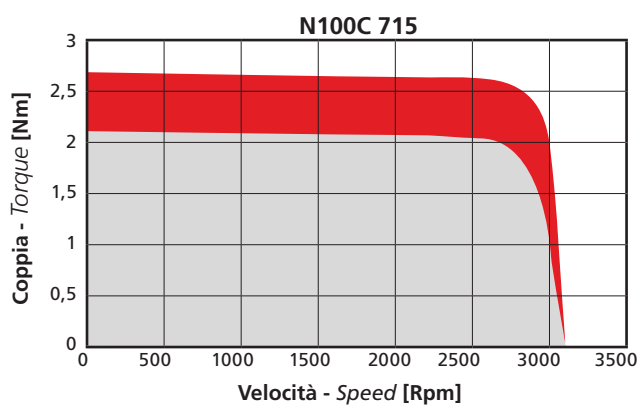
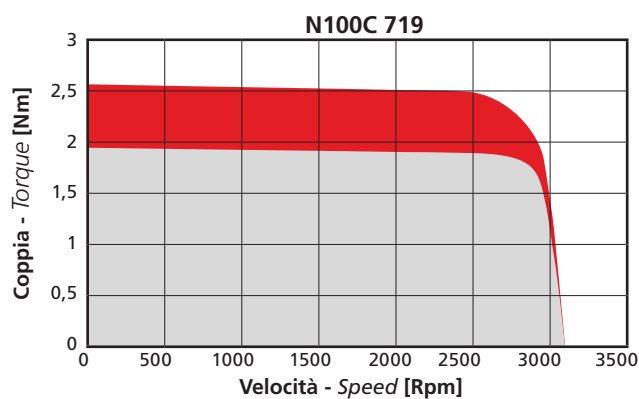
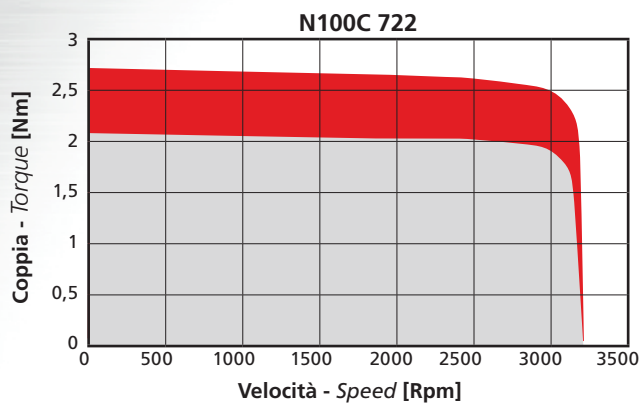

□ S1

■ S2, 30 min.

Designazione motore

Purchasing Code

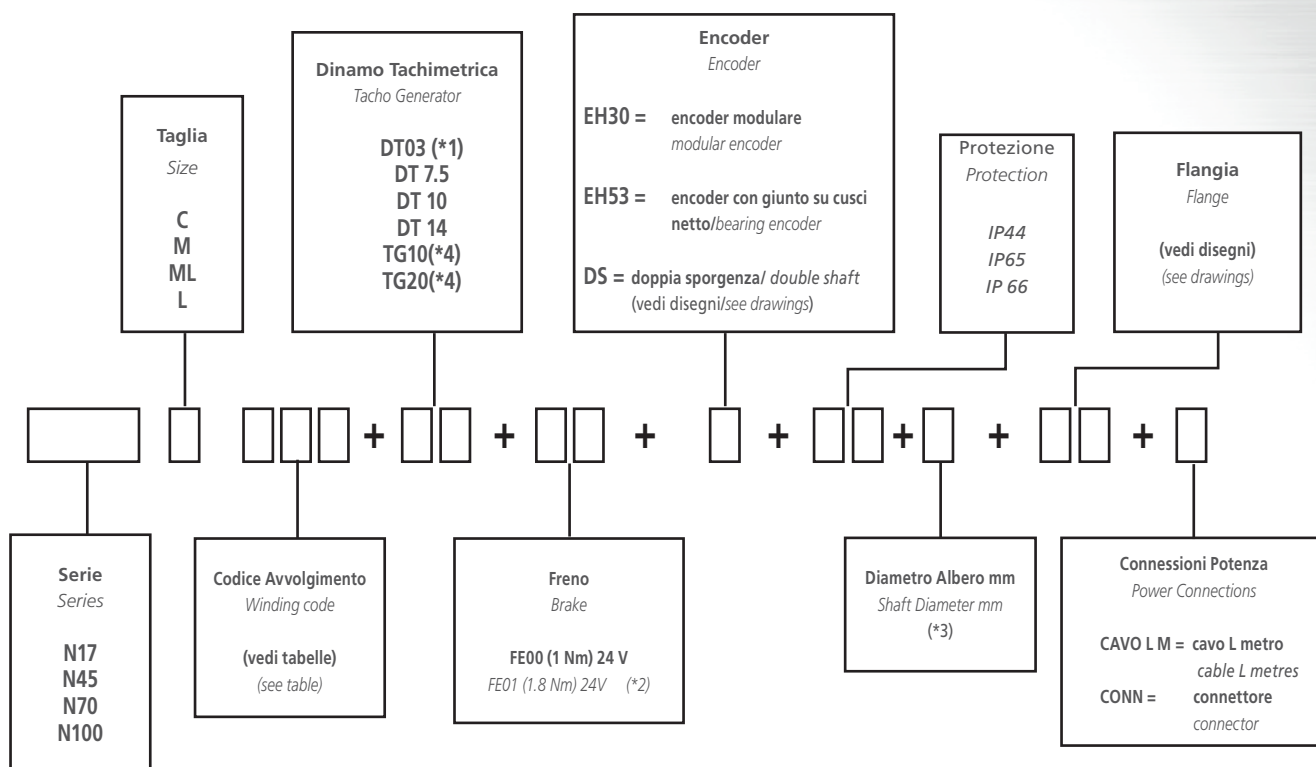

(*1) Disponibile solo per la serie N17.
Available only for N17 series.

(*2) Disponibile solo per la serie N70 e N100.
Available only for N70 and N100 series.

(*3) Nelle serie N70 e N100 è possibile avere motori con flangiature ibride (es. PAM 56B14 con albero =11 mm).
N70 and N100 are available with mixed coupling system (eg. PAM 56B14 flange with shaft = 11 mm).

(*4) Dinamo a 4 poli - Disponibile solo per serie N70 e N100.
4 poles tacho generator – available only for N70 and N100 series

Tipo Encoder Encoder Type	Conteggio Count	ppr	Canali Channels	Logica Logic	Alimentazione Power Supply
EH30	Incrementale Incremental	4 ÷ 1000	A,B,Z	Push Pull line driver	5 ÷ 24 Vdc
EH53	Incrementale Incremental	4 ÷ 2000	A,B,Z	Push Pull line driver	5 Vdc / 8 ÷ 24 Vdc

Esempio di designazione

N70C721 DT10 + FE00 + EH30 + IP44 + DA11X23 + 56B14 + CONN

Questa designazione definisce un motore con le seguenti caratteristiche:

- Serie N70
- Taglia C
- Codice di avvolgimento 721 (vedi tabelle)
- Dinamo tachimetrica 10 V/1000 rpm
- Freno con coppia nominale di 1 Nm
- Encoder modulare
- Protezione IP44
- Diametro dell'albero 11x23 mm
- Flangia 56B14
- Connettore di potenza

Purchasing example

N70C721 DT10 + FE00 + EH30 + IP44 + DA11X23 + 56B14 + CONN

This code represents the following motor:

- Series N70
- Size C
- Winding code 721 (see table)
- Tacho generator 10 V/1000 rpm
- Brake with rated torque 1 Nm
- Modular encoder
- IP44 Protection
- Shaft diameter 11x23 mm
- Flange type 56B14
- Power connector