

HALOGEN™ DE2X12 2D MP

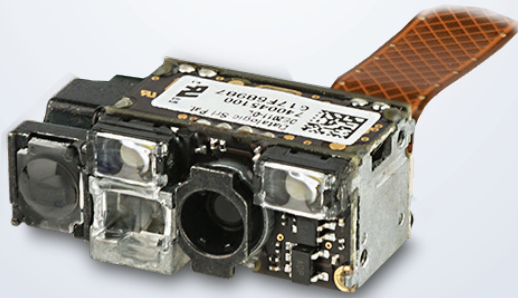

Premium Miniature Scan Engine for OEM applications



THE MINIATURE UNDECODED AREA IMAGER ENGINE

The Halogen™ DE2X12 is a family of ultra-compact high performance 2D MP imager scan engines. The Halogen DE2X12-SR scan engine features a long reading range which surpasses most of the laser scan engines available, making it easier for current 1D laser users to migrate to 2D imaging technology. The Halogen DE2X12-MR has extended reading range out to 5 m / 16.4 ft for industrial applications. The Halogen DE2X12-DL scan engine can read high density bar codes at a closer distance. The Halogen DE2X12-WA scan engine features a different lens system allowing a wide angle field of view with high quality image capture for demanding applications in a compact solution.

The DE2X12 delivers outstanding motion tolerance and decodes poorly printed bar codes as well as bar codes displayed on mobile devices.

The small size of this engine makes it ideal for OEM use in size-constrained environments. It includes the same footprint and mounting hole positions as the Halogen DE2011-DL WVGA 2D scan engine.

Datalogic's 'Green Spot' technology for good-read feedback is an optional feature that provides customers with visual confirmation of a good read.

EASY INTEGRATION

Each model is available in either a parallel (DE2012) or an industry standard MIPI (DE2112) video interface. This allows integrators maximum flexibility to use the DE2X12 scan engine in a wide variety of platforms.

All Halogen DE2X12 models can be connected to the DB0431 OEM Decoder Board to form a high performance Decoded solution with both USB and RS-232 interfaces. This provides Datalogic industry-leading decoding capability in a compact and versatile form factor.

With the use of the Datalogic Software Decoder for Engines (DSDE), customers can integrate the undecoded Halogen DE2X12 OEM scan engine into their device. The DSDE is available for Windows, WinCE, Linux and Android™ operating systems.

FEATURES

- Compact size is able to fit into space constrained application environments
- Same footprint and mounting hole positions as the DE2011-DL scan engine
- Highly visible center cross with four corner dots aiming system
- White illumination
- Options to read bar codes at medium distances (SR), long distances (MR), or high density (DL)
- Options to have the camera parallel interface or the industry standard MIPI interface
- Snappy reading performance with high motion tolerance
- Excellent reading of 1D or 2D codes on printed materials or displayed on mobile devices and computer screens
- Low power consumption
- Datalogic's Software Decoder for Engines (DSDE) includes:
 - Datalogic Decoding Library for Engines (DDLE) with decoding algorithms and engine control functions
 - API documentation and includes files for DDLE
 - Source code of referenced drivers for I2C and camera interface
 - Source code of Demo Application program
- Datalogic's 'Green Spot' technology for visual good-read feedback (optional)
- Sold in packages of 10

INDUSTRY - APPLICATION

- OEM Applications:
 - Self-Service Kiosks
 - Medical / Laboratory Devices
 - Lottery Terminals
 - POS Terminals
 - Access Control Devices
 - Small Wireless Scanning Devices
 - Handheld Terminals and PDAs
 - Automated Data Capture Devices



HALOGEN™ DE2X12 2D MP

TECHNICAL SPECIFICATIONS

DECODING CAPABILITY

1D / Linear Codes	Auto discriminates all standard 1D codes including GS1 DataBar™ linear codes.
2D Codes	Aztec Code; China Han Xin Code; Data Matrix; MaxiCode; Micro QR Code; QR Code
Postal Codes	Australian Post; British Post; China Post; IMB; Japanese Post; KIX Post; Korea Post; Planet Code; Postnet; Royal Mail Code (RM4SCC)
Stacked Codes	EAN/JAN Composites; GS1 DataBar Composites; GS1 DataBar Expanded Stacked; GS1 DataBar Stacked; GS1 DataBar Stacked Omnidirectional; MacroPDF; MicroPDF417; PDF417; UPC A/E Composites

ELECTRICAL

Current (Parallel Models)	Operating (RMS Typical): 220 mA Standby/Idle (RMS Typical): 20 mA Low Power (RMS Typical): 0.2 mA
Current (MIPI Models)	Operating (RMS Typical): 290 mA Standby/Idle (RMS Typical): 30 mA Low Power (RMS Typical): 0.2 mA
Input Voltage	3.3 +/- 0.3 VDC at 23 °C

ENVIRONMENTAL

Ambient Light	0 - 100,000 lux
Humidity (Non-condensing)	5 - 95%
Shock	2500 G at 23 °C at 0.85 m sec.
Temperature	Operating: -30 to 55°C / -22 to 131 °F Storage/Transport: -40 to 70 °C / -40 to 158 °F

INTERFACES

Interfaces	Parallel or MIPI video port on a 21 pin ZIF connector
-------------------	---

PHYSICAL CHARACTERISTICS

Dimensions	Nominal:	11.4 H x 21.0 W x 15.75 D mm 0.45 H x 0.83 W x 0.62 D in
	Maximum:	11.8 H x 21.5 W x 16.0 D mm 0.46 H x 0.85 W x 0.63 D in
Dimensions with Green Spot	Nominal:	11.4 H x 28.0 W x 16.6 D mm 0.45 H x 1.10 W x 0.65 D in
	Maximum:	11.8 H x 28.6 W x 16.9 D mm 0.46 H x 1.13 W x 0.67 D in
Weight		9.0 g / 0.32 oz 11.5 g / 0.41 oz (with Green Spot)

SOFTWARE INTEGRATION

Operating System Support	WinCE; Android; Windows; Linux
Tools	Datalogic Software Decoder for Engines (DSDE)

Dimensions of Scan Engine (Measurements in Millimeters)

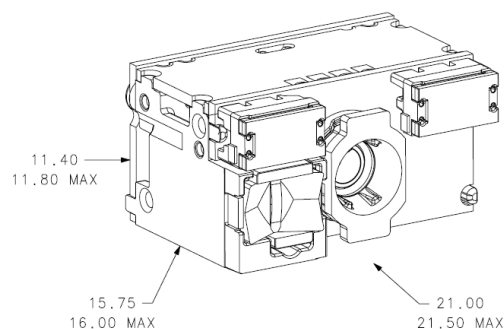

READING PERFORMANCE

Imager Sensor	MP: 1280 x 960 pixels
Light Source	Aiming: 650 nm VLD Illumination: White LEDs
Print Contrast (Minimum)	25%
Field of View	DL & SR models: 42°H x 32°V MR models: 30°H x 23°V WA models: 52°H x 40°V
Reading Angle	Pitch: +/- 60°; Roll (Tilt): +/- 180°; Skew (Yaw): +/- 60°
Reading Indicators	Datalogic 'Green Spot' Technology for visual good-read confirmation (Optional)
Resolution (Maximum)	1D Linear: 2.5 mils (DL and WA) - 3 mils (SR and MR) Data Matrix: 6 mils (DL and WA) - 7.5 mils (SR and MR) PDF417: 3 mils (DL and WA) - 6.6 mils (SR and MR)

READING RANGES

Typical Depth of Field	Minimum distance determined by symbol length and scan angle. Printing resolution, contrast, and ambient light dependent.
1D/2D Codes: DL Models	3 mils Code 39: 6.5 to 20.0 cm / 2.5 to 7.8 in 5 mils Code 39: 3.5 to 29.0 cm / 1.3 to 11.4 in 10 mils Data Matrix: 7.5 to 26.0 cm / 2.9 to 10.2 in 13 mils EAN-13: 4.5 to 42.0 cm / 1.7 to 16.5 in 15 mils Data Matrix: 5.5 to 32.0 cm / 2.1 to 12.5 in 20 mils Code 39: up to 60.0 cm / up to 23.6 in
1D/2D Codes: SR Models	3 mils Code 39: 13.0 to 22.0 cm / 5.1 to 8.6 in 5 mils Code 39: 8.5 to 36.0 cm / 3.3 to 14.1 in 10 mils Data Matrix: 10.0 to 28.0 cm / 3.9 to 11.0 in 13 mils EAN-13: 4.5 to 74.0 cm / 1.7 to 29.1 in 15 mils Data Matrix: 6.5 to 40.0 cm / 2.5 to 15.7 in 20 mils Code 39: up to 110.0 cm / up to 43.3 in
1D/2D Codes: WA Models	3 mils Code 39: 5.0 to 18.0 cm / 2.0 to 7.1 in 5 mils Code 39: 3.0 to 24.0 cm / 1.2 to 9.4 in 10 mils Data Matrix: 4.0 to 20.0 cm / 1.6 to 7.9 in 13 mils EAN-13: 3.5 to 37.0 cm / 1.4 to 14.6 in 15 mils Data Matrix: 3.0 to 25.0 cm / 1.2 to 9.8 in 20 mils Code 39: up to 60.0 cm / up to 23.6 in
1D/2D Codes: MR Models	5 mils Code 39: 20.0 to 55.0 cm / 7.9 to 21.7 in 10 mils Data Matrix: 20.0 to 45.0 cm / 7.9 to 17.7 in 13 mils EAN-13: 8.0 to 100.0 cm / 3.1 to 39.4 in 20 mils Code 39: up to 160 cm / up to 63.0 in 55 mils Data Matrix: up to 160 cm / up to 63.0 in 100 mils Code 39: up to 500 cm / up to 197 in 160 mils Data Matrix: up to 400 cm / up to 158 in

SAFETY & REGULATORY

Environmental Compliance	Complies to China RoHS; Complies to EU RoHS
Laser Classification	Caution Laser Radiation - Do not stare into beam IEC 60825 Class 2

WARRANTY

Warranty	1-Year Factory Warranty
-----------------	-------------------------

