

# ASCO™ STEPPER MOTOR PINCH VALVE

3-WAY - ON / OFF

SERIES  
**S370-XA01X1900VU**

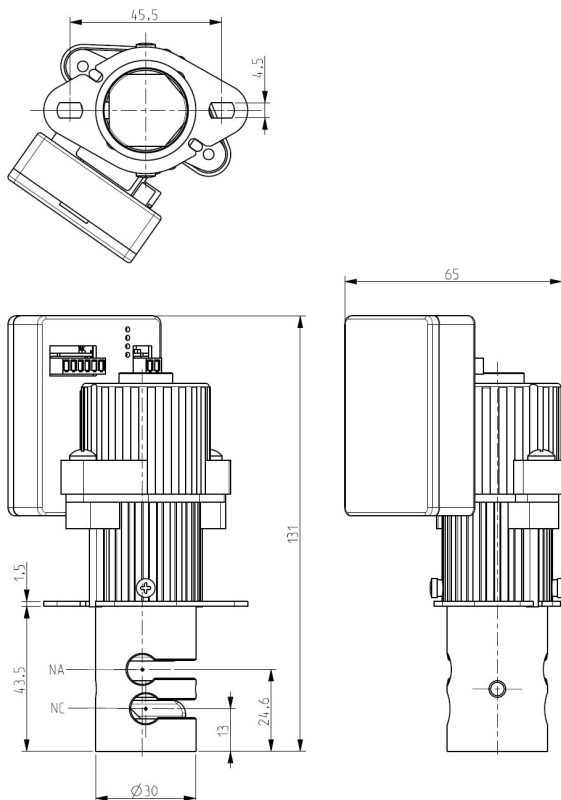

## General Features

Stepper motor pinch valve, suitable to shut off media without producing neither turbulent flows, nor dead spaces.

Particularly suitable for most of the analytical, medical and food applications.

The “OPEN” and “CLOSE” positions of the valve will be set as indicated in the section “OPERATING INSTRUCTIONS”

The system allows a bi-directional through flow and a high flow rate.

The valve is suitable for elastic tubings with hardness up to 90 Shore A.

**The tubing (not included in our supply) is the only material in contact with the fluid.**

Materials (of the pinching device)	
Body	Anodized aluminium
Pinching device	POM (reinforced acetal copolymer)
Engine cover	PA (Polyamide)
Board cover	PA (Polyamide)

Led Indications	
Red	Alarm / Malfunction
Yellow	Valve closed
Green	Valve open
Blue	Programming mode

Electric Features	
Power supply	[12÷24] V
Continuous duty	ED 100%
Minimum Step	0.033mm/step
Insulation class	B (130°C)
Ambient temperature	-10°C +60°C
Electric connection	Molex pitch 2.54mm 6 pins Molex pitch 2.54mm 2 pins
Protection degree	IP 40 (EN60529)

TUBINGS*		Pinching strength (N)	Opening/closing speed (mm/s)	Series and type	Power absorption (W)	Notes	Weight (kg)
Orifice size (mm)	Max O.D. (mm)			Valve	In operation		
6,4	9,5	up to 80	3,33	<b>S370XA01X1900VU</b>	9	-	0,25

## Notes

\* For use with different tubings, the min/max opening of the pinching device can be modified as indicated in the Maintenance Instructions.

As an alternative, it is also possible to order the valves already programmed, with the desired strokes.

- Some data, e.g. actuating time and power absorption, are directly depending on the electronic control and can vary accordingly.
- Valve position fixed on loss of power. “Fail Saving” function available on demand.

**Connection**

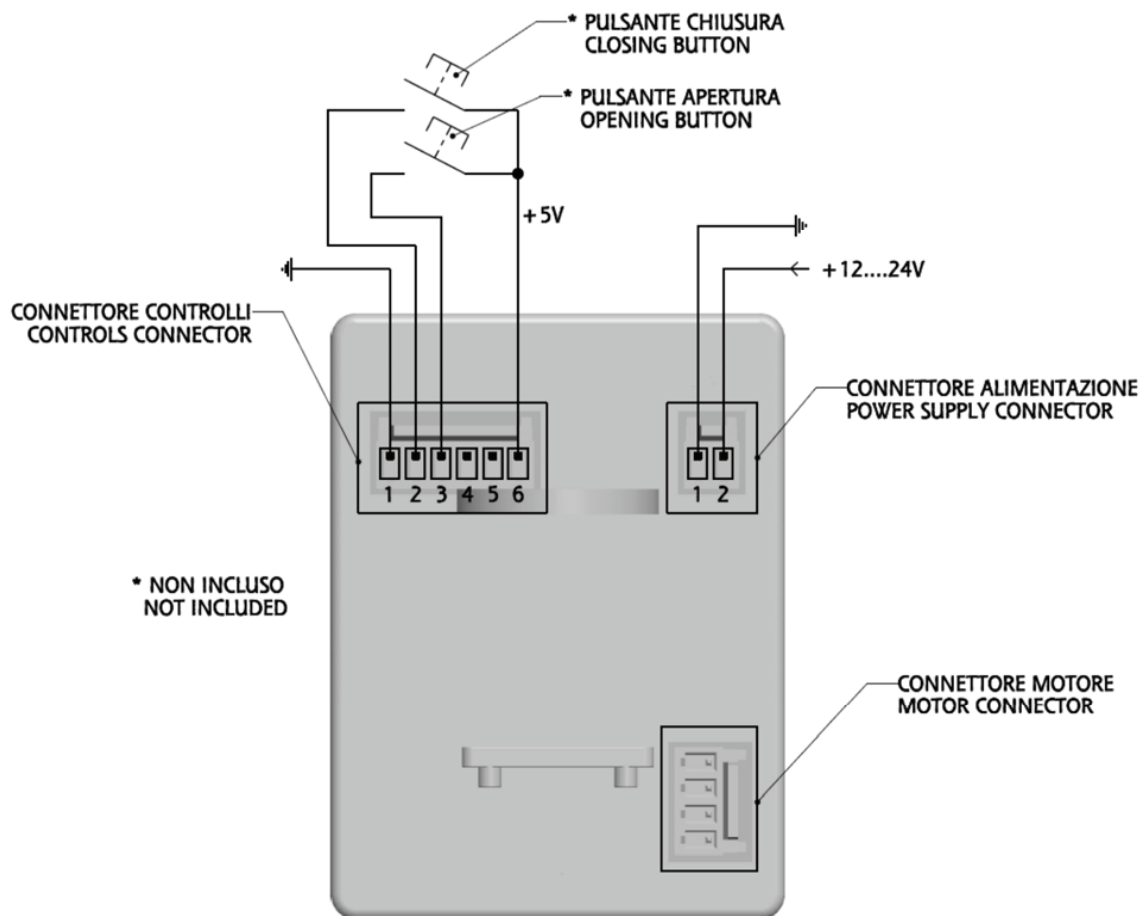

**Operating Instructions**

When power is supplied, the valve will not move and the red LED will be on.

By simultaneously providing the opening and closing pulses, the valve will reset (red, yellow and green LEDs on) and will automatically move to OPEN position (red and yellow LEDs off).

1. Insert the tube in the upper slot
2. Provide a closing command and insert the tube in the lower slot

The valve is now operational and by providing the opening or closing pulse (minimum 10ms), the valve will act accordingly.

LED signals meaning:

- Green LED on -> upper slot open – lower slot closed
- Yellow LED on -> upper slot closed – lower slot open

**Notes**

- Valve position fixed on loss of power.
- When the power will be restored, the valve will not move and the red LED will be on.
- Remove the tube from the lower slot. If the current position of the valve makes it difficult to remove the tube, use the closing command to facilitate this operation. During this phase, the yellow and red LEDs will be on.
- After removing the tube, provide simultaneously the opening and closing pulses, so that the valve resets (red, yellow and green LEDs on). This way, the valve will automatically move to OPEN position (red and yellow LEDs off). Perform a closing command and insert the tube in the lower slot.

THE VALIDITY OF REPORTED DATA IS REFERRED TO THE DATE OF ISSUE. POSSIBLE UPDATES ARE AVAILABLE ON REQUEST