

ASCO™ SOLENOID VALVE

2/2 NORMALLY CLOSED – PILOT OPERATED - G 3/8

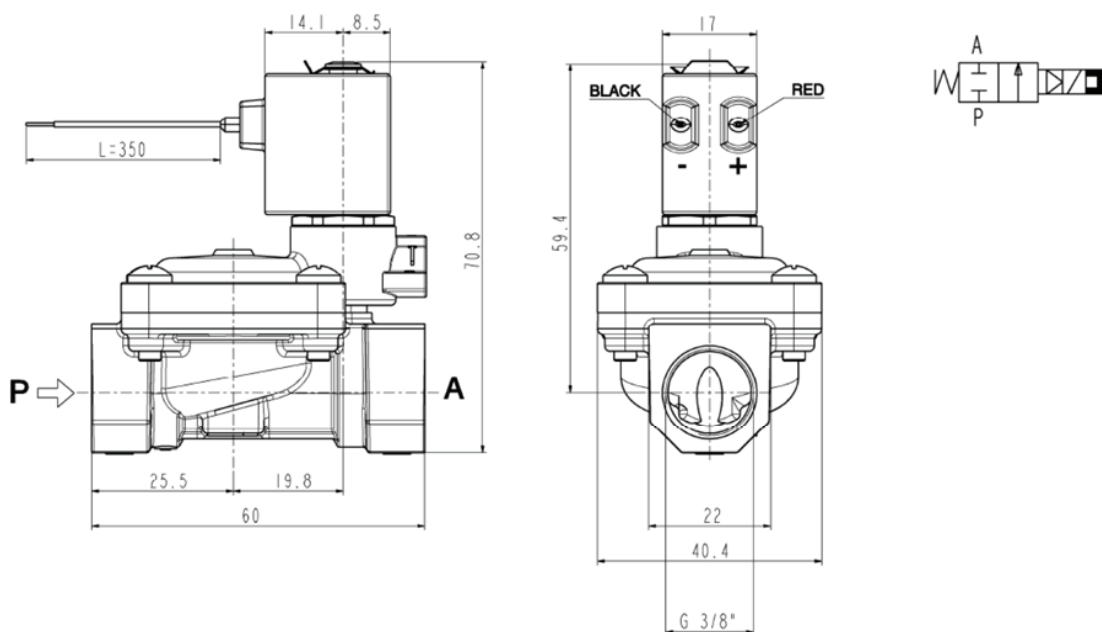

General Features

Diaphragm valve, pilot operated, having full orifice.
 Suitable to shut off liquid and gaseous fluids (verify the compatibility of fluid with materials in contact).

Technical Features	
Maximum allowable pressure (PS)	16 bar
Opening time	~300 ms
Closing time	~1000ms
Fluid temperature	-10°C +90°C
Max viscosity	5°E (~37 cStokes or mm²/s)

Materials in Contact with Fluid	
Body	Brass
Sealing	NBR
Internal components	Brass and stainless steel
Seat	Brass
Guide assembly	Stainless steel

Coil	
Duty	Latching model, polarized type, operating with impulses
Minimum energizing time	20ms
Encapsulation material	PP-V0 (self-extinguishing-polypropylene)
Coil insulation class	A (105°C)
Ambient temperature	-10°C +60°C
Electric connections	N° 2 wires AWG 24 length 350 mm.
Protection degree	IP 66 (EN 60529)
Voltages	DC 6-12V (+10% -10%) (Other voltages on request)

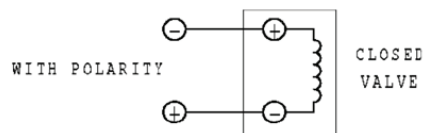
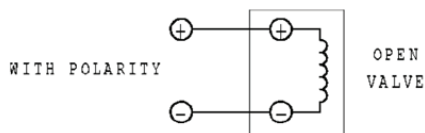

Port size ISO 228	Orifice size (mm)	Differential pressure (bar)				Kv (m³/h)	Series and type		Power absorption			Sealings	Notes	Weight (kg)	
		Δp min	Δp max		Valve		Coil	AC (VA)		DC (W)					
			Gases	Liquids				Inrush	Holding						
G 3/8	13,5	0,35	-	8	-	8	2,5	L182B74	Z075M	-	-	1,2	NBR	-	0,300

Notes

- Sealings : NBR = Nitrile-butylene elastomer
- Operation with gaseous media, at high pressure without any outlet restriction, can reduce the diaphragm life.

LATCHING MODEL

SERIES
L182-B74

ASCO™ SOLENOID VALVE
2/2 NORMALLY CLOSED – PILOT OPERATED - G 3/8

Spare Parts

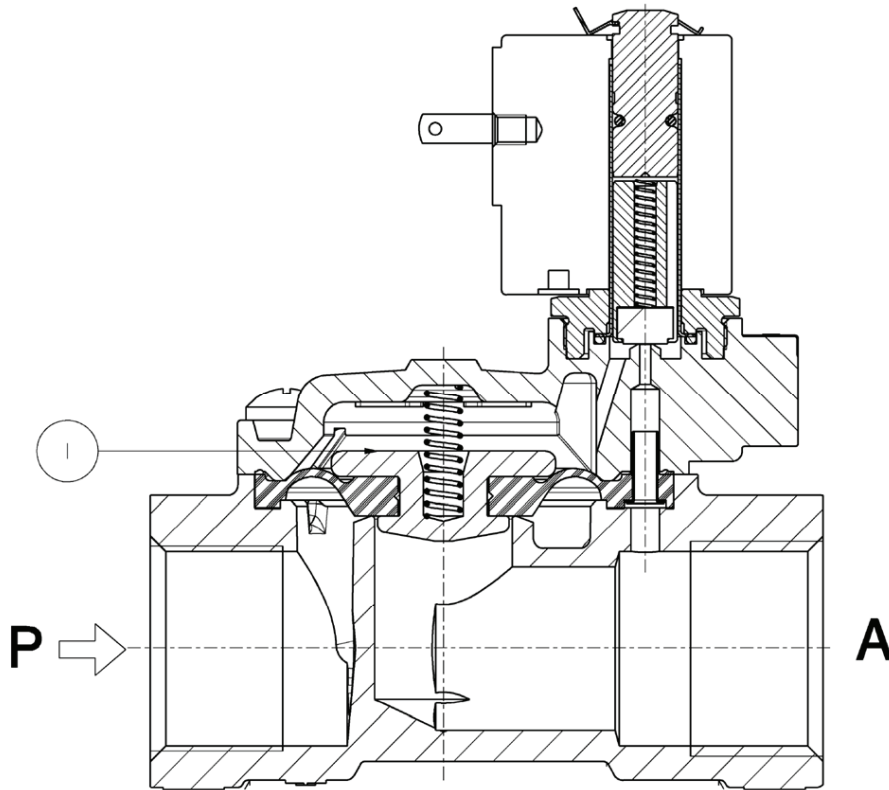

Kit description	Kit P.N.	Consisting of:
Diaphragm assembly	2844302R	Diaphragm assembly pos. 1

Installation

- Solenoid valve can be mounted in any position; vertical with coil upwards preferred.

THE VALIDITY OF REPORTED DATA IS REFERRED TO THE DATE OF ISSUE. POSSIBLE UPDATES ARE AVAILABLE ON REQUEST