

# Synchronous motors

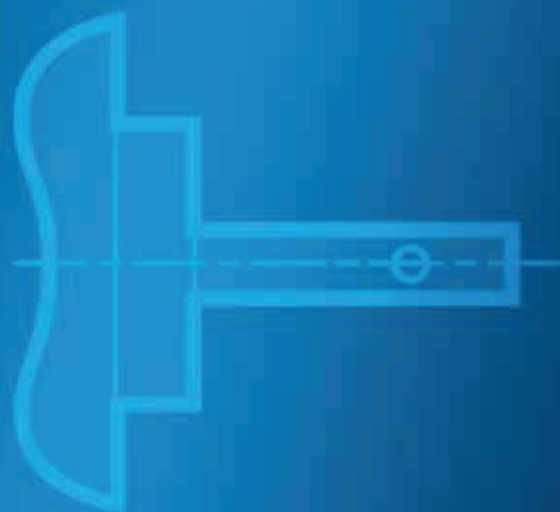

# Guide to selecting synchronous motors







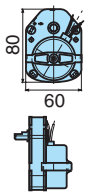
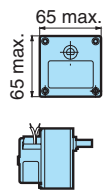

Gearbox		Max. torque (Nm)		0.5		2	
		Type of gearbox		81 021		81 033	
Motors direct drive (Nm)							
Usable Power (W)	Nominal torque (Nm)	Nominal speed (rpm)	Supply voltage (V)	Motor type dimensions (mm)			
<b>Single direction</b>							
0.16	2.5	600	230	▶ p.100 82 340 Ø 47	▶ p.112 82 344 	▶ p.114 82 304 	
					0.001 ... 60 rpm	0.003... 32 rpm	
0.42	8	600	230	▶ p.101 82 330 Ø 47	▶ p.110 82 334 	▶ p.114 82 305 	
					0.001 ... 60 rpm	0.003... 32 rpm	
<b>Reversible: 2 directions</b>							
0.31	12	250	230	▶ p.102 82 510 Ø 36/50	▶ p.120 82 514 	▶ p.124 82 519 	
0.52	10	500			0.5... 50 rpm	0.16... 20 rpm	
0.98	37.5	250	230	▶ p.104 82 520 Ø 51/75	▶ p.122 82 524 	▶ p.126 82 529 	
1.12	30	375			0.8... 60 rpm	0.33... 15 rpm	
1.37	55	250	230	▶ p.106 82 530 Ø 58/79			
2.65	106	250	230	▶ p.108 82 540 65x65			

## Selection of a geared motor

A geared motor is selected according to the required usable power output.

$$\text{Usable Power (W)} = \frac{2\pi}{60} C \cdot n \quad (\text{Nm}) \quad (\text{rpm})$$

A geared motor must have usable power equal to or greater than the power required to rotate the load. It is selected by checking that the point corresponding to the required operating conditions (torque and speed output) is higher than the nominal torque versus speed curve of the geared motor. The required torque output of a geared motor must be within its maximum recommended torque for continuous duty.

3		5	
81 023		81 037	
			
▶ p.116 80 333		▶ p.118 80 337	
			
0.167... 29 rpm		0.24... 24 rpm	
▶ p.128 80 513		▶ p.132 80 517	
			
0.069... 24 rpm		0.1... 20 rpm	
▶ p.130 80 523		▶ p.132/134 80 527	
			
0.069... 12 rpm		0.1... 30 rpm	
▶ p.130 80 533			
			
0.069... 12 rpm		▶ p.134 80 547	
			
		0.1... 20 rpm	

# Some principles of synchronous motors

## Why choose a synchronous motor ?

To produce a certain number of movements within a well defined time period - in this case, the motor is used as a time base.

To produce a rotation movement requiring relatively low torque at reasonable cost.

## How to select from the Crouzet range

The Crouzet synchronous range consists of the following motor types :

### → 1 Single direction

Either :

- clockwise (CW or SA)
- or anti-clockwise (ACL or SI)

(We will see below how to ensure the correct direction of rotation). In special applications it is possible to dispense with the anti-return totally (SAR version). In this case, the motor may rotate in a clockwise direction.

### → 2 Reversible

The motor rotates in either a clockwise or an anti-clockwise direction. The direction of rotation is controlled by a capacitor.

## Definition of a synchronous motor

This motor is characterised by a constant speed of rotation which is independent of the load but linked to the supply frequency.

A synchronous motor maintains its speed of rotation until an overload occurs.

When overload occurs, the motor loses synchronisation, ie. it stops and develops an oscillation (vibration).

### → Speed of rotation

This basic characteristic can be calculated as below :

$$\text{Speed (in rpm)} = \frac{60 \times f \text{ (en Hz)}}{P}$$

f Hz : The frequency of the AC voltage through the coil.

P : The number of pole pairs in the motor  
(1 pair = 1 North Pole + 1 South Pole).

**Therefore the speed of rotation of a synchronous motor is defined by its construction.**

### Example :

A motor equipped with 5 pole pairs would give :

$$V = \frac{60 \times 50}{5} = 600 \text{ rpm using a 50 Hz supply}$$

and

$$V = \frac{60 \times 60}{5} = 720 \text{ rpm using US supply (60 Hz)}$$

## → Construction of a permanent magnet synchronous motor

### Single direction

### Technology

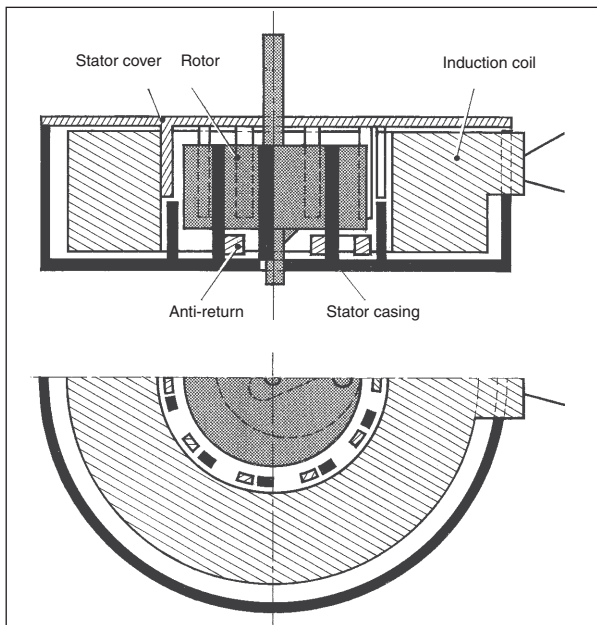

- Casing poles S.N.S.N.S.N
- ▨ Cover poles N.S.N.S.N.S

Our single direction motors are only available with a mechanical anti-return. This assembly offers the double advantage of being a relatively simple technical design while offering good performance.

The permanent magnet rotor has at its periphery a number of alternating NORTH and SOUTH poles equal to the number of poles on the stator. The latter, energised by a single coil connected to an AC supply, produces a magnetic asymmetry which positions the rotor when stopped in such a way that it is attracted by an oscillating torque when the current is switched on.

This start-up condition would cause the motor to turn in either direction if a mechanical device called an «anti-return» did not define and impose the direction of rotation.

### → Principle of operation

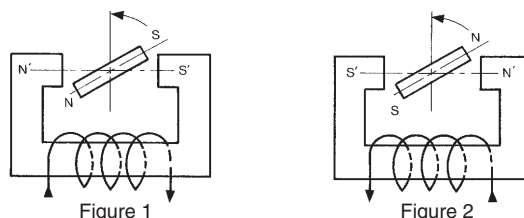

The principle assumes an electro-magnet : a permanent NS magnet rotates around axis O in the air-gap of the electro-magnet, perpendicular to the lines of magnetic force.

Let us suppose that this moving permanent magnet reaches the position marked in figure 1. If the relative positions of the electro-magnet poles are as shown in this figure, the magnet will be repelled and tend to oscillate around an equilibrium position at 180° to direction SN'.

When the permanent magnet is just past this position (figure 2) and the polarity of the electro-magnet is reversed, the magnet will be repelled and return to its previous position, and so on.

By energising the electro-magnet with an AC current of frequency  $f$ , the magnet will turn at a speed of  $f$  revolutions per second.

In these circumstances, a motor can start up in either direction. To determine a particular direction, a mechanical device (anti-return) is placed on the rotor to ensure that the motor operates only in the direction required. There are several types of anti-return device which are differentiated by the degree of the reverse rotation angle within which the rotor can move.

**Reversible**  
**(Also called reversible synchronous motor)**

**Technology**

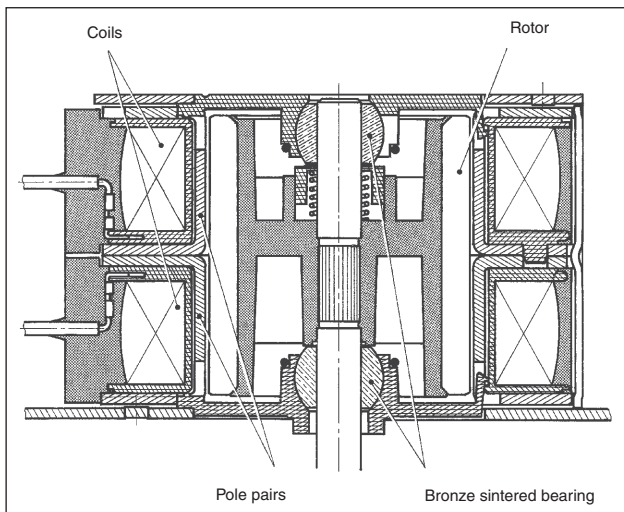

Synchronous motors with a single-phase AC voltage and a permanent magnet must have, for reverse operation, at least 2 stators and 2 coils. Reverse operation can be achieved electrically using a single-pole switch.

A capacitor is used on reversible synchronous motors with 2 coils to produce an electrical dephasing of  $90^\circ$  between the 2 coils. This creates a circular revolving magnetic field. Component precision assures a perfectly circular field and ensures silent motor operation.

**→ Wiring diagram for capacitor**

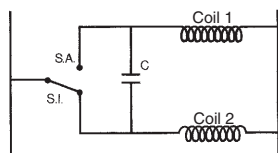

The capacitor specification must be appropriate to each type of motor and to the supply voltage. An incorrect capacitor may distort the magnetic field and have detrimental effects on the reliability of the start-up of the motor as well as on operational quality.

The curve (motor reversing curve) below shows the limits within which the motor will always start in relation to variation in supply voltage and the capacitor values.

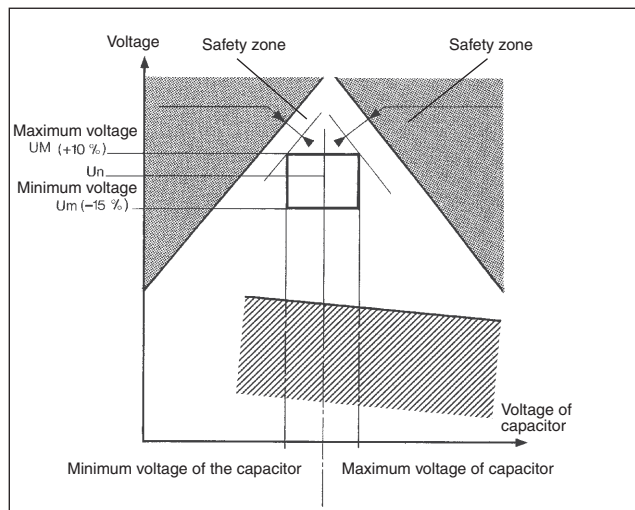

- Nominal voltage of capacitor
- ▨ Zone within which the direction of the motor on starting is not controllable
- ▩ Zone within which the motor will not start

The zone within which the motor operates, ie. the area around the nominal voltage of the capacitor, must be completely controlled by the manufacturer.

Operating within this zone guarantees starting and operating in the direction selected by the user.

As the diagram shows, we build our motors so that the operating zone is as far as possible from the critical zones, whatever the nature of the torque.

**Boosted winding**

Our experience in this area allows us, in certain cases and depending on the precise specification, to operate outside this zone to produce a higher torque and increase performance by between 30 and 80%. Please consult us.

**→ Motor torque**

2 types of torque can be distinguished.

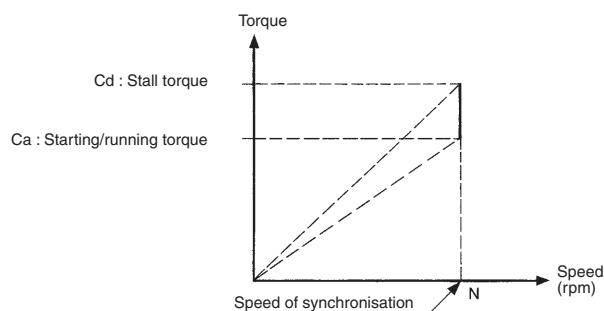

**Starting/running torque (or synchronisation torque)**

This is the torque that a synchronous motor can develop both at start-up and at synchronisation speed.

**N.B:**

In all technical data concerning geared motors in this catalogue, the torque/speed curves indicate the value of the starting/running torque for all the gearbox output speeds.

**Stall torque (or desynchronisation torque)**

This is the torque limit at which a synchronous motor loses its synchronisation.

## Motor and gearbox combination

The motor output shaft turns at a defined speed. This speed is generally too high for the majority of applications.

To reduce this speed we provide users with a complete range of gearboxes, each equipped with a series of ratios.

As a result, the motors can be used for numerous functions.

### → Gearbox characteristics

Each gearbox has been designed for a certain workload. We have defined its potential and its limits for optimum mechanical life.

The principal characteristic is its capacity to absorb a maximum torque in continuous operation.

The range of gearboxes in this catalogue can be used for maximum torques of between 0.5 and 6 N.m for long mechanical lives. The values given are for standard products used in the normal operating conditions specified.

In certain cases, these values can be increased if the required life is reduced. Special cases are dealt with by our design staff.

Each gearbox nevertheless has a limit which is the

### Breakdown torque

This torque, applied to the gearbox, can cause its destruction when first used.

### → Gearbox construction

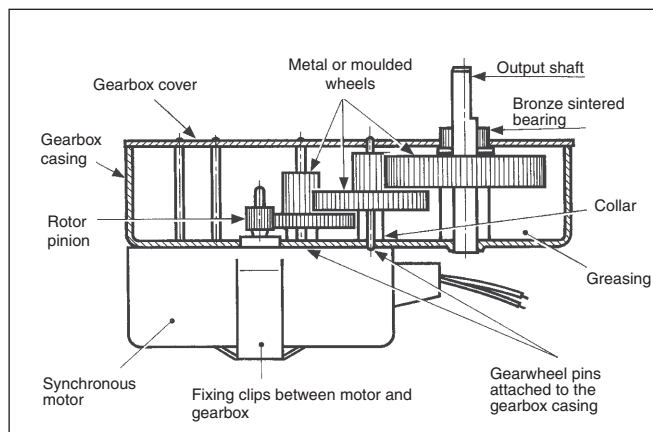

### Selecting a geared motor

Selection is made in relation to the prospective workload.

Before making a selection, it should be remembered that the motor absorbs a certain amount of power, the absorbed power and it cannot deliver more than a fraction of this power : the maximum is defined as the usable power or the mechanical power.

Usable power links 2 factors.

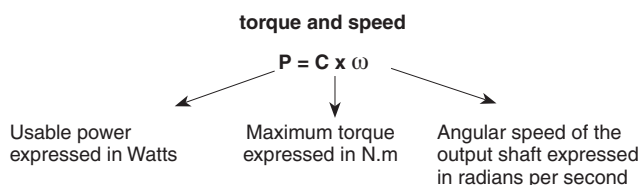

Analysis of this formula clearly shows the function of the gearbox.

It reduces speed and increases torque since the usable power produced by the motor is recovered by the gearbox (within the limits of normal efficiency of course).

The torque requirement thus serves to define the gearbox (characterised by its maximum torque) and the choice of motor depends on the speed at which the torque is required.

The usable power should be borne in mind in all cases, as it is the basic parameter when choosing a motor.

## Addinal information

### → Temperature rise

Permanent magnet motors generally have relatively low efficiency and some of the lost energy is converted into a rise in the temperature of the motor.

We consider that this rise in temperature reaches its maximum level after 2 hours of continuous operation.

To calculate the rise, we use the method known as resistance variation.

$$\Delta T = \frac{\Delta R}{R} (234.5 + T_a) - (T_1 - T_a)$$

**R** = Coil resistance at ambient temperature before applying voltage to the motor (expressed in Ohms - Ω).

**R'** = Resistance of the same coil after 2 hours of continuous motor operation.s

$\Delta R = R' - R$  = Increase in coil resistance.

**T1** = Ambient temperature at the end of the test.

**Ta** = Ambient temperature at the beginning of the test.

### → Dielectric strength

All our products are tested to current standards.

### → Insulation resistance

This is greater than or equal to 75,000 MΩ measured using a 500 VDC current in conditions of ambient temperature and humidity.

### → Safety

Crouzet synchronous motors are designed and manufactured for integration into equipment or machines meeting, for example, the requirements of the Machinery standard : EN 60335-1 (IEC 335-1) : Safety of domestic electrical appliances.

Integration of Crouzet synchronous motors into appliances or machines should, as a rule, take into account the following motor characteristics :

- no earth connection,
- so-called «principal insulation» motors (single insulation)
- protection index : IP40
- insulation class : B.

## Standards and approvals

Our motors are in general designed to conform to international recommendations (IEC), American standards (UL - CSA) and/or European standards (EN).

Proof of compliance with these standards and recommendations is demonstrated by an approval (a mark or certificate of conformity granted by an accredited body) or the manufacturer's declaration of conformity (drafted in accordance with ISO/IEC 22 guidelines).

## Rules and regulations

### → EC directives

Our motors are compatible with European Community directives (Low voltage 73/23 > 50 VAC) and in particular the aspects of electrical safety referred to in the above standard EN 60335 (domestic electrical appliances).

The «CE» mark on all our products is proof of this conformity.

Moreover, our products are particularly suited, for example, to applications concerning both office equipment and medical equipment covered by standards EN 60601 and EN 60950 respectively.

### → Environmental protection

The modern concept of protection of the environment is an integral part of our motors, from product design through to packaging.

## Electromagnetic compatibility

(EC Directive 89/336/EEC dated 03/05/89)

Both asynchronous and synchronous motors and geared motors designed for integration into more complex equipment by professionals, rather than end users, are excluded from the areas of application of this directive.

Crouzet will however be pleased to provide the EMC characteristics of its products on request.



# Direct drive single direction synchronous motors

## → Starting/running torque 2.5 mNm

- Constant speed dependent on supply frequency
- Direction of rotation controlled by long-life mechanical anti-return
- Permanent magnet rotor with 5 pole pairs
- Toughened shaft turning on two moulded polyamide bearings
- UL, CSA (class B) - VDE approved.



### Specifications

Type	82 340 0
Voltages/Frequencies	230 V 50 Hz
<b>Direction of rotation</b>	
Clockwise	82 340 194
Anti-clockwise	82 340 195
<b>General characteristics</b>	
Base speed of motor (rpm)	600
Absorbed power (W)	3
Usable Power (W)	0.16
Starting/running torque (mN.m)	2.5
Stall torque (mN.m)	3.3
Temperature rise (°C)	55
Ambient temperature (°C)	-5 → +60
Maximum inertial load that can be moved (g.cm <sup>2</sup> )	4.6
Number of offload starts 10 <sup>6</sup>	10
Max. reverse rotation angle (°)	360
Insulation resistance (MΩ)	75 x 10 <sup>3</sup>
Breakdown voltage (V-50 Hz)	1800 - 1 s
Weight (g)	110
Wires length mm (approximately)	250
Protection rating	IP30

0.16 watts

82 340 0

230 V 50 Hz

82 340 194

82 340 195

600

3

0.16

2.5

3.3

55

-5 → +60

4.6

10

360

75 x 10<sup>3</sup>

1800 - 1 s

110

250

IP30

### Product adaptations

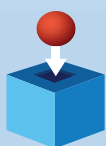

- Pinion on output shaft
- Special supply voltages
- Special cable lengths
- Special connectors

### Dimensions

82 340 0

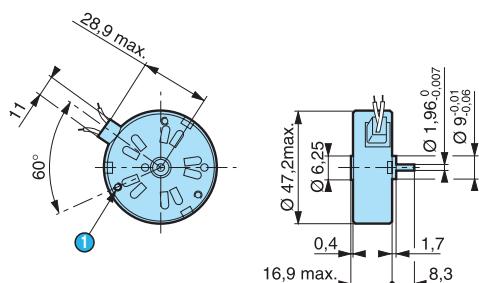

① 3 fixing holes ØM2 at 120 ° on r=19.5 max. depth 2.4 mm

### Other information

The speed of a motor powered by a 60 Hz supply is 20 % higher than that of a motor powered by a 50 Hz supply.

To order, see page 13

# Direct drive single direction synchronous motors

## → Starting/running torque 8 mNm

- Constant speed dependent on supply frequency
- Direction of rotation controlled by long-life mechanical anti-return
- Permanent magnet rotor with 5 pole pairs
- Toughened shaft turning on two moulded polyamide bearings
- UL, CSA (class B) - VDE approved



## Specifications

Type	82 330 5
Voltage / Frequency	230 V - 50 Hz
<b>Direction of rotation</b>	
Clockwise	82 330 582
Anti-clockwise	82 330 583
<b>General characteristics</b>	
Base speed of motor (50 Hz) (rpm)	600
Absorbed power (W)	3.5
Usable Power (W)	0.42
Starting/running torque (mN.m)	8
Stall torque (mN.m)	12
Temperature rise (°C)	55
Ambient temperature (°C)	-5 → +60
Maximum inertial load that can be moved (g.cm <sup>2</sup> )	11
Number of offload starts 10 <sup>6</sup>	10
Max. reverse rotation angle (°)	72
Insulation resistance (MΩ)	75 x 10 <sup>3</sup>
Breakdown voltage (V-50 Hz)	1800 - 1 s
Weight (g)	160
Wires length mm (approximately)	250
Protection rating	IP30

0.42 Watts

## Product adaptations

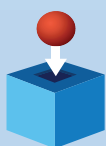

- Pinion on output shaft
- Special supply voltages
- Special cable lengths
- Special connectors

## Dimensions

82 330 5

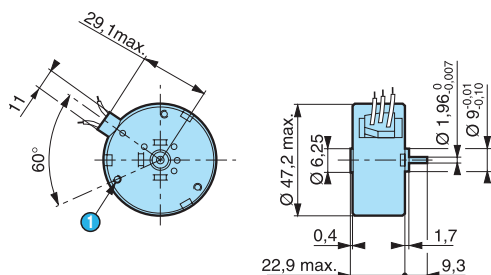

① 3 fixing holes Ø M2 at 120 ° on r=19.5 max. depth 3.5 mm

## Other information

The speed of a motor powered by a 60 Hz supply is 20 % higher than that of a motor powered by a 50 Hz supply.

# Direct drive reversible synchronous motors

## → Starting/running torque 12 mNm

- Constant speed, dependant upon supply frequency
- Direction of rotation controlled by dephasing capacitor
- Sintered bearing lubricated for life
- Silent operation
- UL, CSA (class B) - VDE approved.



### Specifications

	2.7 Watts	2.7 Watts
Type	82 510 0	82 510 5
Voltages/Frequencies	230 - 240 V 50 Hz	230 - 240 V - 50/60 Hz
<b>Part numbers</b>	<b>82 510 0</b>	<b>82 510 5</b>
<b>General characteristics</b>		
Base speed of motor (rpm)	250	500
Absorbed power (W)	2.7	2.7
Usable Power (W)	0.31	0.52
Starting/running torque (mN.m)	12	10
Stall torque (mN.m)	15	12
Temperature rise (°C)	55	65
Ambient temperature (°C)	-10 +75	-5 +65
Maximum inertial load that can be moved (g.cm <sup>2</sup> )	22	22
Number of offload starts	∞	∞
Insulation resistance (MΩ)	75x10 <sup>3</sup>	75x10 <sup>3</sup>
Breakdown voltage (V-50 Hz)	1800-1 sec	1800-1 sec
Weight (g)	90	90
Wires length mm (approximately)	250	250
Protection rating	IP40	IP40

### Product adaptations

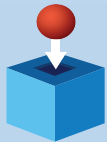

- Special output shafts
- Pinion on output shaft
- Special supply voltages
- Special cable lengths
- Special output bearings
- Special mounting plate
- Special connectors

## Accessories

Voltages/Frequencies	$\mu\text{F}$	V	Code
Capacitors motors 82 510 0/3			
230-240 V - 50 Hz	$0.33 \pm 10 \%$	400	26 231 801
115 V - 50/60 Hz	$0.27 \pm 10 \%$	250	26 231 851
24 V - 50 Hz	$8.2 \pm 10 \%$	70	26 231 711
24 V - 60 Hz	$6.8 \pm 10 \%$	63	26 231 708
Capacitors motor 82 510 5/8			
230-240 V 50/60 Hz	$0.39 \pm 10 \%$	630	26 231 924
115 V - 50/60 Hz	$0.39 \pm 10 \%$	630	26 231 924
24 V - 50/60 Hz	$8.2 \pm 10 \%$	70	26 231 711

## Dimensions

82 510 0

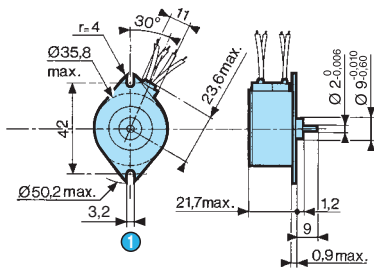

① 2 fixing holes  $\varnothing 3.2$

82 510 5

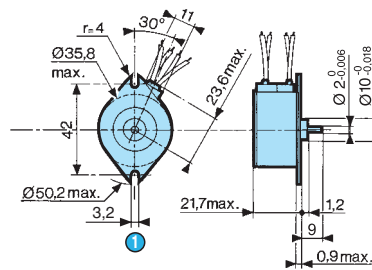

① 2 fixing holes  $\varnothing 3.2$

## Connections

In parallel  
Motors 82 510 0

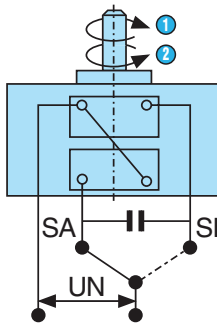

① SA : Clockwise  
② SI : Anti-clockwise

In series  
Motors 82 510 0/5 only  
230 V - 240 V 50 Hz version

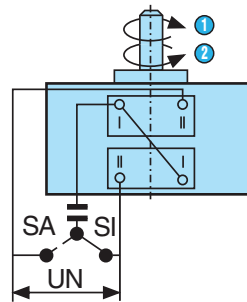

① SA : Clockwise  
② SI : Anti-clockwise

## Other information

The speed of a motor powered by a 60 Hz supply is 20 % higher than that of a motor powered by a 50 Hz supply.

# Direct drive reversible synchronous motors

→ Starting/running torque from 30 and 37.5 mN.m

- Constant speed, dependent on supply frequency
- Direction of rotation controlled by dephasing capacitor
- Sintered bearing lubricated for life
- Silent operation
- UL, CSA (classe B) - VDE approved



## Specifications

	3.5 Watts	3.5 Watts
Type	82 520 0	82 520 4
Voltages/Frequencies	230-240 V 50 Hz	230-240 V 50 Hz
<b>Part numbers</b>	<b>82 520 014</b>	<b>82 520 4</b>
<b>General characteristics</b>		
Base speed of motor (rpm)	250	375
Absorbed power (W)	3.5	3.5
Usable Power (W)	0.98	1.12
Starting/running torque (mN.m)	37.5	30
Stall torque (mN.m)	42	31
Temperature rise (°C)	55	55
Ambient temperature (°C)	-10+75	-10+75
Maximum inertial load that can be moved (g.cm <sup>2</sup> )	33	33
Number of offload starts	∞	∞
Insulation resistance (MΩ)	75x10 <sup>3</sup>	75x10 <sup>3</sup>
Breakdown voltage (V-50 Hz)	1800 -1 sec.	1800 -1 sec.
Weight (g)	210	210
Wires length mm (approximately)	250	250
Protection rating	IP40	IP40

## Product adaptations

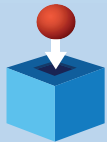

- Special output shafts
- Pinion on output shaft
- Special supply voltages
- Special cable lengths
- Special output bearings
- Special mounting plate
- Special connectors

To order, see page 13

## Accessories

Voltages/Frequencies	$\mu\text{F}$	V	Code
Capacitors motor 82 520 0			
230-240 V - 50 Hz	$0.10 \pm 10 \%$	700	26 231 941
115 V 60 Hz	$0.33 \pm 10 \%$	400	26 231 801
24 V - 50 Hz	$8.2 \pm 10 \%$	70	26 231 711
Capacitors motor 82 520 4			
230/240 V - 50 Hz	$0.12 \pm 10 \%$	600	26 231 903
115 V - 60 Hz	$0.39 \pm 5 \%$	630	26 231 924
24 V - 50 Hz	$15 \pm 5 \%$	70	26 231 728
24 V - 60 Hz	$12 \pm 5 \%$	63	26 231 145

## Dimensions

### 82 520 0

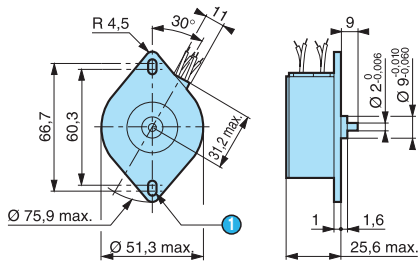

1 2 oblong fixing holes 3.5 wide

## Connections

### In parallel

Motors 82 520 0 - 82 520 4

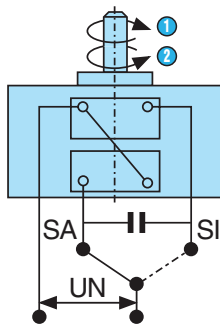

1 SA : Clockwise

2 SI : Anti-clockwise

## Other information

The speed of a motor powered by a 60 Hz supply is 20 % higher than that of a motor powered by a 50 Hz supply.

# Direct drive reversible synchronous motors

## → Starting/running torque 55 mN.m

- Constant speed, dependent on supply frequency
- Direction of rotation controlled by dephasing capacitor
- Sintered bearing lubricated for life
- Silent operation
- UL, CSA (class B) - VDE approved.



### Specifications

Type	82 530 0
Voltage / Frequency	230-240 V 50 Hz
Part numbers	82 530 0
<b>General characteristics</b>	
Base speed of motor (rpm)	250
Absorbed power (W)	3.6
Usable Power (W)	1.37
Starting/running torque (mN.m)	55
Stall torque (mN.m)	58
Temperature rise (°C)	45
Ambient temperature (°C)	-10 → +85
Maximum inertial load that can be moved (g.cm <sup>2</sup> )	130
Number of offload starts	∞
Insulation resistance (MΩ)	75x10 <sup>3</sup>
Breakdown voltage (V-50 Hz)	1800 -1 sec.
Weight (g)	340
Wires length mm (approximately)	250
Protection rating	IP40

3.6 Watts

82 530 0

230-240 V 50 Hz

82 530 0

### Product adaptations

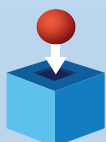

- Special output shafts
- Pinion or bush on output shaft
- Special supply voltages
- Special cable lengths
- Special output bearings
- Special mounting plate
- Special connectors

To order, see page 13



# Direct drive reversible synchronous motors

## → Starting/running torque 106 mN.m

- Constant speed, dependent on supply frequency
- Direction of rotation controlled by dephasing capacitor
- Sintered bearing lubricated for life
- Silent operation
- UL, CSA (class B) - VDE approved.



### Specifications

Type	82 540 0
Voltages/Frequencies	230-240 V 510 Hz
<b>Part numbers</b>	<b>82 540 0</b>
<b>General characteristics</b>	
Base speed of motor (rpm)	250
Absorbed power (W)	7.2
Usable Power (W)	2.65
Starting/running torque (mN.m)	106
Stall torque (mN.m)	118
Temperature rise (°C)	60
Ambient temperature (°C)	-10 +70
Maximum inertial load that can be moved (g.cm <sup>2</sup> )	180
Number of offload starts	∞
Insulation resistance (MΩ)	75x10 <sup>3</sup>
Breakdown voltage (V-50 Hz)	1800 -1 sec.
Weight (g)	540
Wires length (mm)	250
Protection rating	IP40

7.2 Watts

82 540 0

230-240 V 510 Hz

82 540 0

### Product adaptations

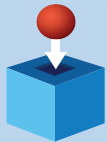

- Special output shafts
- Pinion on output shaft
- Special supply voltages
- Special cable lengths
- Special output bearings
- Special mounting plate
- Special connectors

## Accessories

Voltages/Frequencies	$\mu\text{F}$	V	Code
Capacitors motor 82 540 0			
230-240 V 50 Hz	$0.22 \pm 5 \%$	630	26 231 909
115 V - 60 Hz	$0.56 \pm 5 \%$	400	26 231 822
24 V - 50 Hz	$22 \pm 10 \%$	63	26 231 703
24 V - 60 Hz	$15 \pm 5 \%$	70	26 231 728

## Dimensions

82 540 0

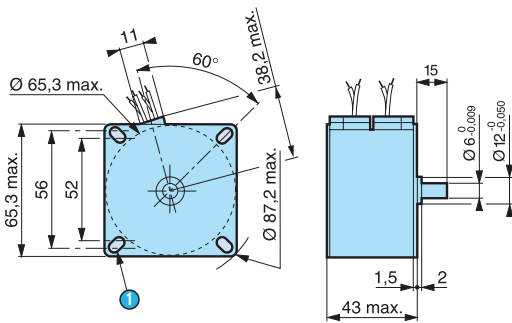

- ① 4 oblong fixing holes 4.2 mm wide

## Connections

In parallel  
Motors 82 540 0

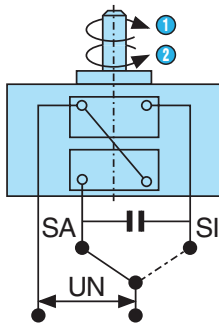

- ① SA : Clockwise  
② SI : Anti-clockwise

## Other information

The speed of a motor powered by a 60 Hz supply is 20 % higher than that of a motor powered by a 50 Hz supply.

# Single direction synchronous geared motors

→ 0.5 Nm 3.5 Watts

- Mechanical strength : 0.5 Nm
- Constant speed, dependent on supply frequency
- Wide range of speeds available
- Direction of rotation controlled by long-life mechanical anti-return device
- Permanent magnet rotor



## Specifications

	3.5 Watts	3.5 Watts	3.5 Watts	3.5 Watts
Type	82 334 5	82 334 5	82 334 5	82 334 5
Direction of rotation	Anti-clockwise	Clockwise	Anti-clockwise	Clockwise
Voltages/Frequencies	230 V 50 Hz	230 V 50 Hz	240 V 50 Hz	240 V 50 Hz
<b>Output speed</b>	<b>Ratios (i)</b>			
60 rpm	10	82 334 734	82 334 726	82 334 811
50 rpm	12	●	●	●
30 rpm	20	82 334 728	82 334 736	82 334 805
20 rpm	30	82 334 730	82 334 738	82 334 807
15 rpm	40	82 334 731	82 334 739	82 334 808
12.5 rpm	48	●	●	●
12 rpm	50	82 334 733	82 334 741	82 334 810
10 rpm	60	82 334 756	82 334 764	82 334 772
7.5 rpm	80	82 334 758	82 334 766	82 334 774
6 rpm	100	82 334 759	82 334 767	82 334 775
5 rpm	120	82 334 760	82 334 768	82 334 776
4 rpm	150	82 334 769	82 334 761	82 334 785
3 rpm	200	●	●	●
2.5 rpm	240	●	●	●
2 rpm	300	82 334 748	82 334 742	82 334 796
1 rpm	600	82 334 744	82 334 751	82 334 792
0.80 rpm	750	●	●	●
0.5 rpm	1200	●	●	●
0.33 rpm	1800	●	●	82 334 794
0.25 rpm	2400	●	●	●
0.20 rpm	3000	●	●	●
0.10 rpm	6000	●	●	●
5.00 rph	7200	●	●	●
4.00 rph	9000	●	●	●
3.00 rph	12000	●	●	●
2.50 rph	14400	●	●	●
1.00 rph	36000	●	●	●
0.50 rph	72000	●	●	●
1/12 rph	432000	●	●	●
1/24 rph	864000	●	●	●
<b>General characteristics</b>				
Motor	82 340 0	82 340 0	82 340 0	82 340 0
Gearbox	81 021 0	81 021 0	81 021 0	81 021 0
Maximum permitted torque from gearmotor under continuous conditions for 1 millions turns of the gearmotor (Nm)	0.5	0.5	0.5	0.5
Axial load static (daN)	1	1	1	1
Radial load static (daN)	8	8	8	8
Absorbed power (W)	3	3	3	3
Motor output (W)	0.16	0.16	0.16	0.16
Maximum temperature rise (°C)	55	55	55	55
Ambient temperature (°C)	-5 → +60	-5 → +60	-5 → +60	-5 → +60
Weight (g)	160	160	160	160
Wires length mm (approximately)	250	250	250	250
Protection rating	IP40	IP40	IP40	IP40

To order, see page 13

## Product adaptations

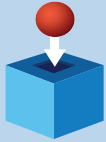

- Special supply voltages
- Special cable lengths
- Special connectors
- Special output shafts
- Special gearbox ratios
- Special gear wheel material
- Special output bearings

## Curves

Graph of torque versus speed 82 334 5

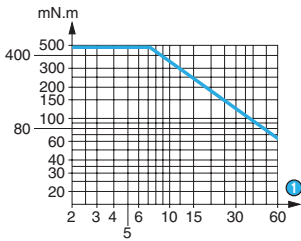

① RPM

## Dimensions

82 334 5

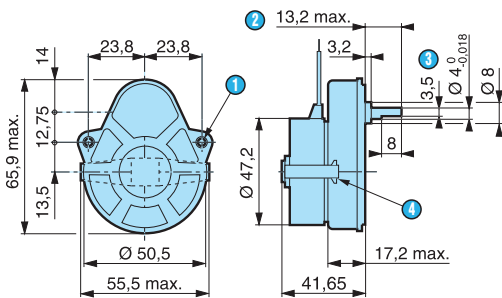

- ① 2 fixing holes  $\text{Ø } 3.2$
- ② (pushed-in shaft)
- ③ 3.5 across flat
- ④ Fixing clip

## Options

Shaft 79 200 967

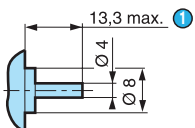

- ① (pushed-in shaft ←)

Shaft 79 200 779

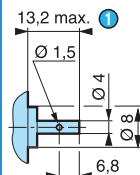

- ① (pushed-in shaft ←)

Shaft 70 999 421 SP1295-10

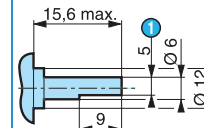

- ① Across flat

## Other information

The speed of a motor powered by a 60 Hz supply is 20 % higher than that of a motor powered by a 50 Hz supply.

# Single direction synchronous geared motors

→ 0.5 Nm 3 Watts

- Mechanical strength : 0.5 Nm
- Constant speed, dependent on supply frequency
- Wide range of speeds available
- Direction of rotation controlled by long-life mechanical anti-return device
- Permanent magnet rotor



## Specifications

	3 Watts	3 Watts	3 Watts	3 Watts
Type	82 344 0	82 344 0	82 344 0	82 344 0
Direction of rotation	Anti-clockwise	Anti-clockwise	Clockwise	Clockwise
Voltages/Frequencies	230 V 50 Hz	240 V 50 Hz	230 V 50 Hz	240 V 50 Hz
<b>Output speed</b>	<b>Ratios (i)</b>			
60 rpm	10	82 344 744	82 344 736	82 344 698
50 rpm	12	●	●	●
50 rpm	20	82 344 738	82 344 746	82 344 692
20 rpm	30	82 344 740	82 344 748	82 344 694
15 rpm	40	82 344 741	82 344 749	82 344 695
12.5 rpm	48	●	●	●
12 rpm	50	82 344 743	82 344 751	82 344 697
10 rpm	60	82 344 752	82 344 760	82 344 706
7.5 rpm	80	82 344 754	82 344 762	82 344 708
6 rpm	100	82 344 755	82 344 763	82 344 709
5 rpm	120	82 344 756	82 344 764	82 344 710
4 rpm	150	82 344 765	82 344 767	82 344 719
3 rpm	200	82 344 766	82 344 768	82 344 720
2.5 rpm	240	●	●	●
2 rpm	300	82 344 775	82 344 768	82 344 729
1 rpm	600	82 344 771	82 344 778	82 344 725
0.80 rpm	750	●	●	●
0.5 rpm	1200	82 344 772	82 344 779	82 344 726
0.33 rpm	1800	82 344 773	82 344 780	82 344 727
0.25 rpm	2400	●	●	●
0.20 rpm	3000	●	●	●
0.10 rpm	6000	●	●	●
5.00 rph	7200	●	●	●
4.00 rph	9000	●	●	●
3.00 rph	12000	●	●	●
2.50 rph	14400	●	●	●
1.00 rph	36000	●	●	●
0.50 rph	72000	●	●	●
1/12 rph	432000	●	●	●
1/24 rph	864000	●	●	●
<b>General characteristics</b>				
Motor	82 340 0	82 340 0	82 340 0	82 340 0
Gearbox	81 021 0	81 021 0	81 021 0	81 021 0
Maximum permitted torque from gearmotor under continuous conditions for 1 millions turns of the gearmotor (Nm)	0.5	0.5	0.5	0.5
Axial load static (daN)	1	1	1	1
Radial load static (daN)	8	8	8	8
Absorbed power (W)	3	3	3	3
Motor output (W)	0.16	0.16	0.16	0.16
Maximum temperature rise (°C)	55	55	55	55
Ambient temperature (°C)	-5 → +60	-5 → +60	-5 → +60	-5 → +60
Weight (g)	160	160	160	160
Wires length mm (approximately)	250	250	250	250
Protection rating	IP40	IP40	IP40	IP40

To order, see page 13

## Product adaptations

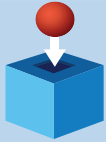

- Special supply voltages
- Special cable lengths
- Special connectors
- Special output shafts
- Special gearbox ratios
- Special gear wheel material
- Special output bearings

## Curves

Graph of torque versus speed 82 344 0

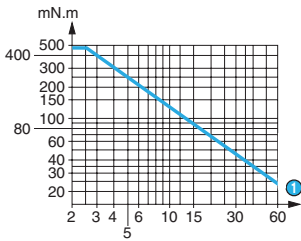

① RPM

## Dimensions

82 344 0

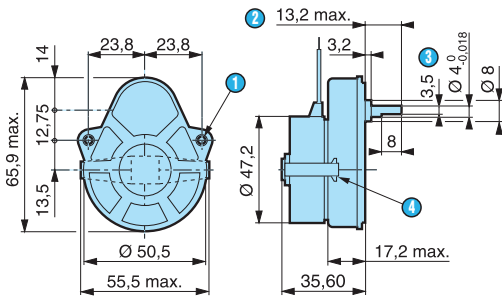

- ① 2 fixing holes  $\text{Ø } 3.2$
- ② (pushed-in shaft)
- ③ 3.5 across flat
- ④ Fixing clip

## Options

Shaft 79 200 967

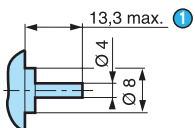

- ① (pushed-in shaft ←)

Shaft 79 200 779

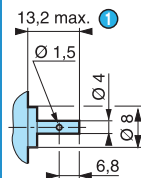

- ① (pushed-in shaft ←)

Shaft 70 999 421 SP1295-10

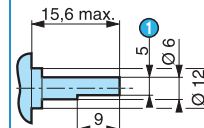

- ① Across flat

## Other information

The speed of a motor powered by a 60 Hz supply is 20 % higher than that of a motor powered by a 50 Hz supply.

# Single direction synchronous geared motors

→ 2 Nm 3 and 3.5 Watts

- Mechanical strength : 2 Nm
- Constant speed, dependent on supply frequency
- Wide range of speeds available
- Direction of rotation controlled by long-life mechanical anti-return
- Permanent magnet rotor
- Silent operation
- UL, CSA, VDE approved, comply with IEC standards



## Specifications

		3 Watts	3.5 Watts
Type		82 304 0	82 305 5
Voltage / Frequency		230 V 50 Hz	230 V 50 Hz
Output speed	Ratios		
32 rpm	18.75	●	●
24 rpm	25	●	●
15 rpm	40	●	●
12 rpm	50	●	●
10 rpm	60	●	●
7.5 rpm	80	●	●
6 rpm	100	●	●
5 rpm	120	●	●
3.75 rpm	160	●	●
2.4 rpm	250	●	●
2 rpm	300	●	●
1.11 rpm	540	●	●
1 rpm	600	●	●
0.75 rpm	800	●	●
0.56 rpm	1080	●	●
0.4 rpm	1500	●	●
0.2 rpm	3000	●	●
0.13 rpm	4800	●	●
0.10 rpm	6000	●	●
3/4 rph	27000	●	●
2/3 rph	54000	●	●
1/5 rph	180000	●	●
General characteristics			
Motor		82 340 0	82 330 5
Gearbox		81 033 0	81 033 0
Maximum permitted torque from gearmotor under continuous conditions for 1 millions turns of the gearmotor (N.m)		2	2
Radial load static (daN)		1	1
Axial load static (daN)		10	10
Absorbed power (W)		3	3.5
Motor output (W)		0.16	0.42
Maximum temperature rise (°C)		55	55
Ambient temperature (°C)		-50 → +60	-50 → +60
Weight (g)		250	300
Wires length mm (approximately)		250	250
Protection rating		IP40	IP40

## Product adaptations

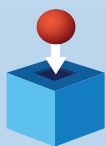

- Special supply voltages
- Special cable lengths
- Special connectors
- Special output shafts
- Special gearbox ratios
- Special gear wheel material
- Special output bearings
- Special mounting plate

To order, see page 13

## Curves

Graph of torque versus speed 82 304 0

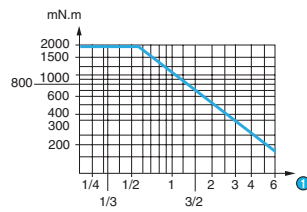

① RPM

Graph of torque versus speed 82 305 0

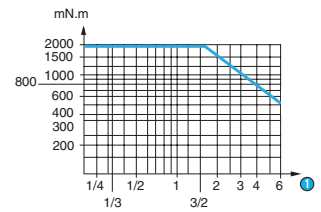

① RPM

## Dimensions

82 304 0 - 82 305 5

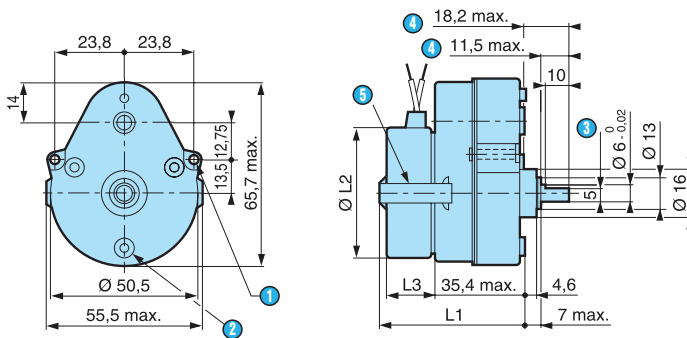

- ① 2 fixing holes Ø 3.2
- ② 3 mounting bosses Ø 7.2 at 120° on radius = 19.5 with 3 holes M3 depth 4
- ③ across flat
- ④ (pushed-in shaft ←)
- ⑤ fixing claw

82 304 0 L1 = 54.8 mm max. / Ø L2 = 47.2 mm max. / L3 = 16.9 mm max.  
 82 305 5 L1 = 59.85 mm max. / Ø L2 = 47.2 mm max. / L3 = 22.9 mm max.

## Options

Shaft 79 202 573

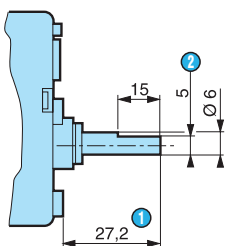

- ① 5 across flat
- ② (pushed-in shaft ←)

## Other information

The speed of a motor powered by a 60 Hz supply is 20 % higher than that of a motor powered by a 50 Hz supply.

# Single direction synchronous geared motors

→ 3 Nm 3.5 Watts

- Mechanical strength : 3 Nm
- Constant speed, dependent on supply frequency
- Wide range of speeds available
- Direction of rotation controlled by long-life mechanical
- Permanent magnet rotor
- UL, CSA, VDE approved, comply with IEC standards



## Specifications

### 3.5 Watts

Type  
Base speed of motor (rpm)  
Voltage / Frequency

80 333 5  
600  
230-240 V - 50 Hz

Output speed (rpm)	Ratios (i)	
29	20.83	●
14	41.66	●
7	83.33	●
4	150	●
3.2	187.5	●
2	300	●
1.6	375	●
1	600	●
0.8	750	●
0.5	1200	●
0.267	2250	●
0.25	2400	●
0.167	3600	●

### General characteristics

Motor	82 330 5
Gearbox	81 023
Maximum permitted continuous rated gearbox output torque (Nm)	3
Axial load static (daN)	2
Radial load static (daN)	3
Absorbed power (W)	3.5
Motor output (W)	0.42
Maximum temperature rise (°C)	55
Ambient temperature (°C)	-5 → +60
Weight (g)	440
Wires length mm (approximately)	250
Protection rating	IP30

## Product adaptations

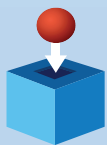

- Special supply voltages
- Special cable lengths
- Special connectors
- Special output shafts
- Special gearbox ratios
- Special gear wheel material
- Special output bearings
- Special mounting plate

## Curves

Graph of torque versus speed 82 333 5

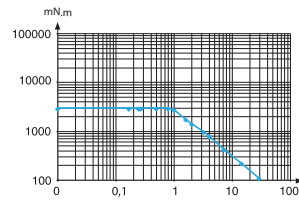

① RPM

## Dimensions

80 333 5

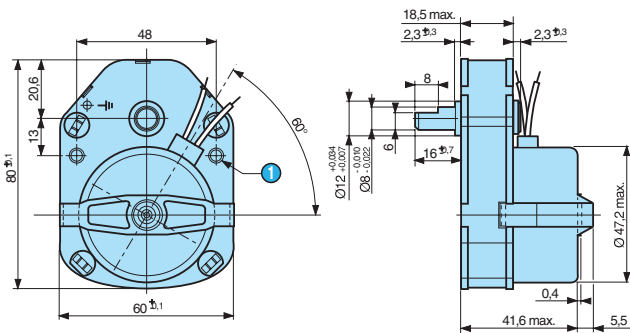

① 2 fixing holes  $\varnothing 4.1$  max.

## Other information

The speed of a motor powered by a 60 Hz supply is 20 % higher than that of a motor powered by a 50 Hz supply.



# Single direction synchronous geared motors

→ 5 Nm 3.5 Watts

- Mechanical strength : 5 Nm
- Constant speed, dependent on supply frequency
- Speeds from 0.24 rpm to 24 rpm
- Direction of rotation controlled by long-life mechanical anti-return
- Permanent magnet rotor
- UL, CSA, VDE approved, comply with IEC standards



## Specifications

			3.5 Watts	3.5 Watts
Type			80 337 5	80 337 5
Voltage / Frequency			230 V 50 Hz	240 V 50 Hz
Direction of rotation	Output speed	Ratios		
Anti-clockwise	24 rpm	25	80 337 506	80 337 524
Anti-clockwise	14.40 rpm	41.66	80 337 509	80 337 534
Anti-clockwise	9.60 rpm	62.5	●	●
Anti-clockwise	7.20 rpm	83.33	●	●
Anti-clockwise	4.80 rpm	125	80 337 514	80 337 528
Anti-clockwise	2.40 rpm	250	80 337 516	80 337 529
Anti-clockwise	1.20 rpm	500	80 337 519	80 337 539
Anti-clockwise	0.80 rpm	750	●	●
Anti-clockwise	0.24 rpm	2500	80 337 523	80 337 541
Clockwise	24 rpm	25	80 337 507	80 337 533
Clockwise	14.40 rpm	41.66	80 337 508	80 337 525
Clockwise	9.60 rpm	62.5	●	●
Clockwise	7.20 rpm	83.33	●	●
Clockwise	4.80 rpm	125	80 337 515	80 337 537
Clockwise	2.40 rpm	250	80 337 517	80 337 538
Clockwise	1.20 rpm	500	80 337 518	80 337 530
Clockwise	0.80 rpm	750	●	●
Clockwise	0.24 rpm	2500	80 337 522	80 337 532
General characteristics				
Motor			82 330 5	82 330 5
Gearbox			81 037 0	81 037 0
Maximum permitted continuous-rated gearbox output torque over 1 million revolutions (N.m)			5	5
Radial load static (daN)			2	2
Axial load static (daN)			3	3
Absorbed power (W)			3.5	3.5
Motor output (W)			0.42	0.42
Maximum temperature rise (°C)			55	55
Ambient temperature (°C)			-5 → +60	-5 → +60
Weight (g)			480	480
Wires length mm (approximately)			250	250
Protection rating			IP40	IP40

## Product adaptations

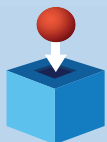

- Special supply voltages
- Special cable lengths
- Special connectors
- Special output shafts
- Special gearbox ratios
- Special gear wheel material
- Special output bearings
- Special mounting plate

To order, see page 13

## Dimensions

80 337 5

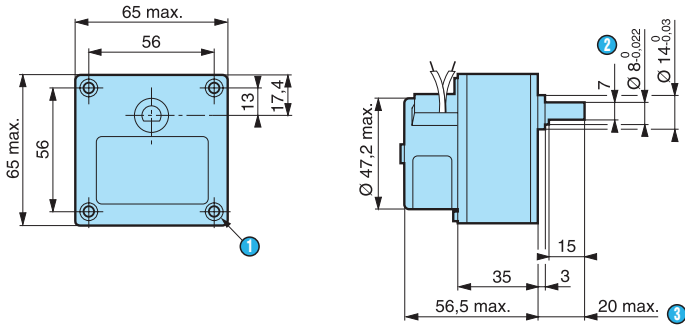

- ① 4 holes M4 depth 12 mm
- ② 7 across flat
- ③ pushed-in shaft

## Options

Shaft 79 206 478

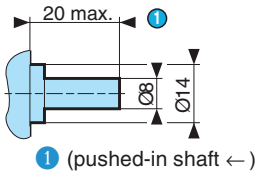

## Other information

The speed of a motor powered by a 60 Hz supply is 20 % higher than that of a motor powered by a 50 Hz supply.

# Reversible synchronous geared motors

→ 0.5 Nm 2.7 Watts

- Mechanical strength : 0.5 Nm
- Constant speed, dependent on supply frequency
- Wide range of speeds available
- Direction of rotation controlled by dephasing capacitor
- Permanent magnet rotor
- UL, CSA, VDE approved, comply with IEC standards.



## Specifications

Type	2.7 Watts		2.7 Watts	
Standard motor speed (rpm)	82 514 0		82 514 5	
Voltage / Frequency	250 230-240 V - 50 Hz		500 230-240 V - 50/60 Hz	
Output speed (250 RPM)	Output speed (500 RPM)	Ratios		
25.00 rpm	50.00 rpm	10	●	●
20.00 rpm	40.00 rpm	25/2	●	●
12.50 rpm	25.00 rpm	20	●	●
10.00 rpm	20.00 rpm	25	●	●
5.00 rpm	10.00 rpm	50	●	●
4.00 rpm	8.00 rpm	125/2	●	●
2.50 rpm	5.00 rpm	100	●	●
2.00 rpm	4.00 rpm	125	●	●
1.25 rpm	2.50 rpm	200	●	●
1.00 rpm	2.00 rpm	250	●	●
0.50 rpm	1.00 rpm	500	●	●
General characteristics				
Motor	82 510 0		82 510 5	
Gearbox	81 021 0		81 021 0	
Base speed of motor (rpm)	250		500	
Maximum permitted continuous rated gearbox output torque for 1 million revolutions of gearbox output shaft (Nm)	0.5		0.5	
Axial load static (daN)	1		1	
Radial load static (daN)	8		8	
Absorbed power (W)	2.7		2.7	
Motor output (W)	0.31		0.52	
Maximum temperature rise (°C)	50		60	
Ambient temperature (°C)	-5 → +70		-5 → +60	
Weight (g)	140		140	
Wires length mm (approximately)	250		250	
Protection rating	IP40		IP40	

## Product adaptations

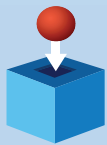

- Special supply voltages
- Special cable lengths
- Special connectors
- Special output shafts
- Special gearbox ratios
- Special gear wheel material
- Special output bearings

## Curves

Graph of torque versus speed 82 514 0

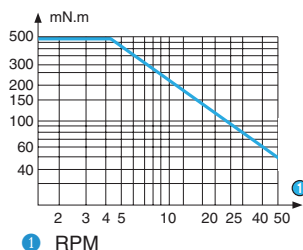

Graph of torque versus speed 82 514 5

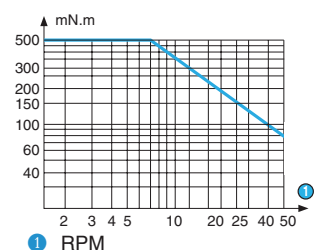

To order, see page 13

## Accessories

Voltages/Frequencies	$\mu\text{F}$	V	Code
<b>Capacitors motor 82 510 0</b>			
230-240 V - 50 Hz	$0.33 \pm 10 \%$	400	26 231 801
115 V - 50/60 Hz	$0.27 \pm 10 \%$	250	26 231 851
24 V - 50 Hz	$8.2 \pm 10 \%$	70	26 231 711
24 V - 60 Hz	$6.8 \pm 10 \%$	63	26 231 708
<b>Capacitors motor 82 510 5</b>			
230-240 V 50/60 Hz	$0.39 \pm 10 \%$	630	21 231 924
115 V 50/60 Hz	$0.39 \pm 10 \%$	630	26 231 924
24 V 50/60 Hz	$8.2 \pm 10 \%$	70	26 231 711

## Dimensions

82 514 0 - 82 514 5

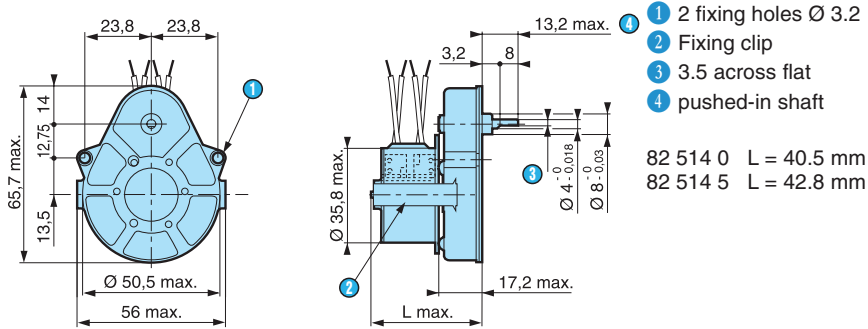

## Options

Shaft 79 200 967

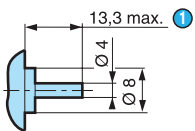

1 (pushed-in shaft ←)

Shaft 79 200 779

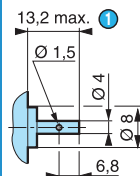

1 (pushed-in shaft ←)

Shaft 70 999 421 SP1295-10

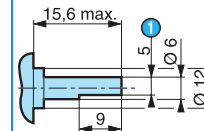

1 5 across flat

## Connections

In parallel  
Motors 82 510 0 - 82 510 5

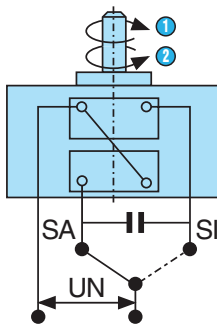

1 SA : Clockwise  
2 SI : Anti-clockwise

In series  
Motors 82 510 0 and 82 510 5  
only 230 V - 240 V 50 Hz version

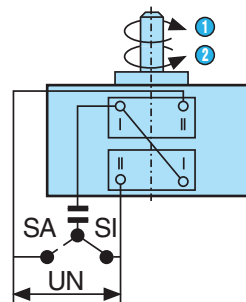

1 SA : Clockwise  
2 SI : Anti-clockwise

## Other information

The speed of a motor powered by a 60 Hz supply is 20 % higher than that of a motor powered by a 50 Hz supply.

# Reversible synchronous geared motors

→ 0.5 Nm 3.5 Watts

- Mechanical strength : 0.5 Nm
- Constant speed, dependent on supply frequency
- Wide range of speeds available
- Direction of rotation controlled by dephasing capacitor
- Permanent magnet rotor
- UL, CSA, VDE approved, comply with IEC standards



## Specifications

Type  
Base speed of motor (rpm)  
Voltage / Frequency

**3.5 Watts**  
82 524 0  
250  
230-240 V - 50 Hz

**3.5 Watts**  
82 524 4  
375  
230-240 V - 50 Hz

Output speed (250 RPM)	Output speed (375 RPM)	Ratios (i)
25.00 rpm	37.50 rpm	10
20.00 rpm	30.00 rpm	25/2
13.33 rpm	20.00 rpm	75/4
12.50 rpm	18.75 rpm	20
10.00 rpm	15.00 rpm	25
5.00 rpm	7.50 rpm	50
4.00 rpm	6.00 rpm	125/2
2.50 rpm	3.75 rpm	100
2.00 rpm	3.00 rpm	125
1.00 rpm	1.50 rpm	250
0.33 rpm	0.50 rpm	750

Part Number	Availability
82 524 001	●
82 524 002	●
82 524 003	●
82 524 004	●
82 524 008	●
82 524 010	●
●	●
●	●
82 524 016	●
●	●

### General characteristics

Motor	82 520 0	82 520 4
Gearbox	81 021 0	81 021 0
Maximum permitted continuous rated gearbox output torque for 1 million revolutions of gearbox output shaft (Nm)	0.5	0.5
Axial load static (daN)	1	1
Radial load static (daN)	8	8
Absorbed power (W)	3.5	3.5
Motor output (W)	0.98	1.12
Maximum temperature rise (°C)	50	50
Ambient temperature (°C)	-5 → +70	-5 → +70
Weight (g)	140	140
Wires length mm (approximately)	250	250
Protection rating	IP40	IP40

## Product adaptations

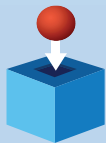

- Special supply voltages
- Special cable lengths
- Special connectors
- Special output shafts
- Special gearbox ratios
- Special gear wheel material
- Special output bearing

## Curves

Torque/speed curves 82 524 0

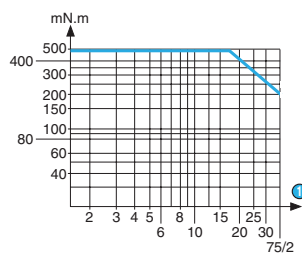

① RPM

Torque/speed curves 82 524 4

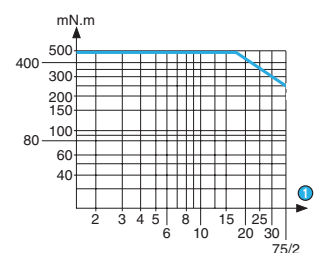

① RPM

To order, see page 13

## Accessories

Voltages/Frequencies	$\mu\text{F}$	V	Code
Capacitors for motor 82 520 0			
230-240 V - 50 Hz	$0.10 \pm 10 \%$	700	26 231 941
115 V 60 Hz	$0.33 \pm 10 \%$	400	26 231 801
24 V - 50 Hz	$8.2 \pm 10 \%$	70	26 231 711
Capacitors motor 82 520 4			
230/240 V - 50 Hz	$0.12 \pm 10 \%$	600	26 231 903
115 V 60 Hz	$0.39 \pm 5 \%$	630	26 231 924
24 V - 50 Hz	$15 \pm 5 \%$	70	26 231 728
24 V - 60 Hz	$12 \pm 5 \%$	63	26 231 145

## Dimensions

82 524 0 - 82 524 4

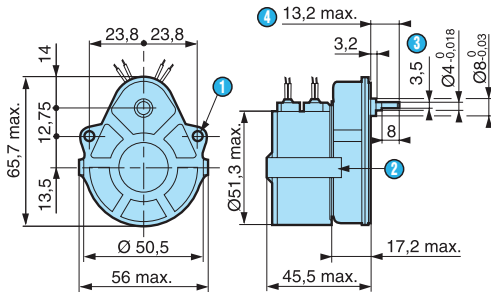

- 1 2 fixing holes  $\text{Ø} 3.2$
- 2 Fixing clip
- 3 3.5 across flat
- 4 pushed-in shaft

## Options

Shaft 79 200 967

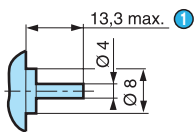

- 1 (pushed-in shaft ←)

Shaft 79 200 779

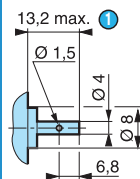

- 1 (pushed-in shaft ←)

Shaft 70 999 421 SP1295-10

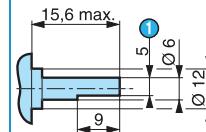

- 1 5 across flat

## Connections

In parallel

Motors 82 520 0 - 82 520 4

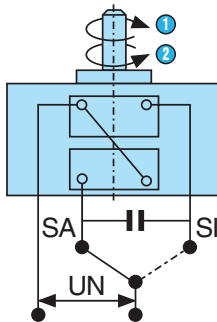

- 1 SA : Clockwise
- 2 SI : Anti-clockwise

## Other information

The speed of a motor powered by a 60 Hz supply is 20 % higher than that of a motor powered by a 50 Hz supply.

# Reversible synchronous geared motors

→ 2 Nm 2.7 Watts

- Mechanical strength : 2 Nm
- Constant speed, dependent on supply frequency
- Wide range of speeds available
- Direction of rotation controlled by dephasing capacitor
- Permanent magnet rotor
- UL, CSA, VDE approved, comply with IEC standards.



## Specifications

	2.7 Watts	2.7 Watts
Type	82 519 0	82 519 5
Voltage / Frequency	230-240 V - 50 Hz	230-240 V - 50/60 Hz
Base speed of motor (rpm)	250	500
<b>Output speed (250 RPM)</b>		
10,00 rpm	●	●
5,00 rpm	●	●
2,50 rpm	●	●
1,00 rpm	●	●
0,50 rpm	●	●
0,33 rpm	●	●
0,16 rpm	●	●
5,00 rev/hr	●	●
<b>Output speed (500 RPM)</b>		
20,00 rpm		
10,00 rpm		
5,00 rpm		
2,00 rpm		
1,00 rpm		
0,66 rpm		
0,32 rpm		
10,00 rev/hr		
<b>Ratios (i)</b>		
25		
50		
100		
250		
500		
750		
1500		
3000		
<b>General characteristics</b>		
Motor	82 510 0	82 510 5
Gearbox	81 033 0	81 033 0
Maximum permitted continuous rated gearbox output torque for 1 million revolutions of gearbox output shaft Nm	2.0	2.0
Axial load static (daN)	1	1
Radial load static (daN)	10	10
Absorbed power (W)	2.7	2.7
Motor output (W)	0.31	0.52
Maximum temperature rise (°C)	50	60
Ambient temperature (°C)	-5 → +70	-5 → +60
Weight (g)	230	230
Wires length mm (approximately)	250	250
Protection rating	IP40	IP40

## Product adaptations

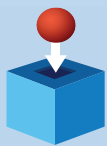

- Special supply voltages
- Special cable lengths
- Special connectors
- Special output shafts
- Special gearbox ratios
- Special gear wheel material
- Special output bearings

## Curves

Graph of torque versus speed 82 519 0

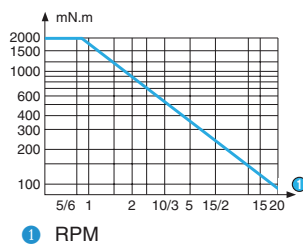

Graph of torque versus speed 82 519 5

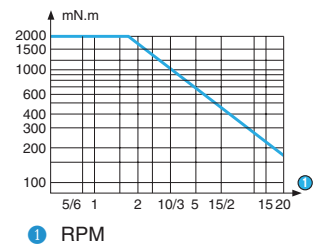

To order, see page 13

## Accessories

Voltages/Frequencies	$\mu\text{F}$	V	Code
Capacitors for motor 82 510 0			
230-240 V - 50 Hz	$0.33 \pm 10 \%$	400	26 231 801
115 V - 50/60 Hz	$0.27 \pm 10 \%$	250	26 231 851
24 V - 50 Hz	$8.2 \pm 10 \%$	70	26 231 711
24 V - 60 Hz	$6.8 \pm 10 \%$	63	26 231 708
Capacitors for motor 82 510 5			
230-240 V - 50/60 Hz	$0.39 \pm 10 \%$	630	26 231 924
115 V - 50/60 Hz	$0.39 \pm 10 \%$	630	26 231 924
24 V - 50/60 Hz	$8.2 \pm 10 \%$	70	26 231 711

## Dimensions

### 82 519 0 - 82 519 5

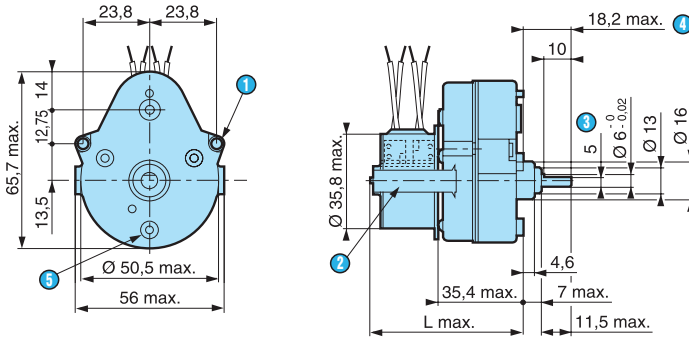

- 1 2 fixing holes  $\text{Ø} 3.2$
- 2 Fixing clip
- 3 5 across flat
- 4 pushed-in shaft

82 519 0 L = 58.7 mm  
82 519 5 L = 61 mm

## Options

### Shaft 79 200 967

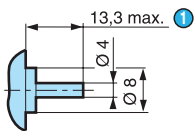

- 1 (pushed-in shaft ←)

### Shaft 79 200 779

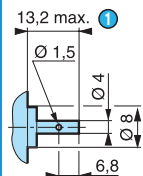

- 1 (pushed-in shaft ←)

### Shaft 79 999 421- SP1295-10

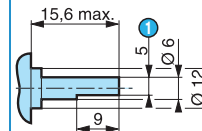

- 1 5 across flat

## Connections

### In parallel

Motors 82 510 0 - 82 510 5

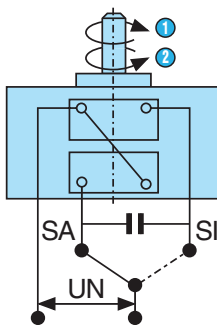

- 1 SA : Clockwise
- 2 SI : Anti-clockwise

### In series

Motors 82 510 0 and 82 510 5 only 230 V - 240 V 50 Hz version

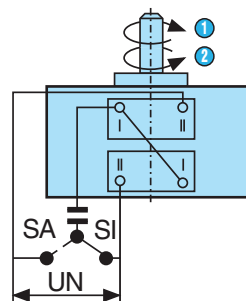

- 1 SA : Clockwise
- 2 SI : Anti-clockwise

## Other information

The speed of a motor powered by a 60 Hz supply is 20 % higher than that of a motor powered by a 50 Hz supply.

# Reversible synchronous geared motors

→ 2 Nm 3.5 Watts

- Mechanical strength : 2 Nm
- Constant speed, dependent on supply frequency
- Wide range of speeds available
- Direction of rotation controlled by dephasing capacitor
- Permanent magnet rotor
- UL, CSA, VDE approved, comply with IEC standards



## Specifications

	3.5 Watts	3.5 watts
Type	82 529 0	82 529 4
Voltage / Frequency	230-240 V - 50 Hz	230-240 V - 50 Hz
Base speed of motor (rpm)	250	375
<b>Output speed (250 RPM)</b>		
<b>Output speed (375 RPM)</b>		
<b>Ratios (i)</b>		
10.00 rpm	●	●
5.00 rpm	●	●
4.00 rpm	-	●
2.50 rpm	●	●
1.00 rpm	●	●
0.50 rpm	●	●
0.33 rpm	●	●
5.00 rev/hr	●	●
<b>General characteristics</b>		
Motor	82 520 0	82 520 4
Gearbox	81 033 0	81 033 0
Maximum permitted continuous rated gearbox output torque for 1 million revolutions of gearbox output shaft Nm	2.0	2.0
Axial load static (daN)	1	1
Radial load static (daN)	10	10
Absorbed power (W)	3.5	3.5
Motor output (W)	0.98	1.12
Maximum temperature rise (°C)	50	50
Ambient temperature (°C)	-5 → +70	-5 → +70
Weight (g)	260	350
Wires length mm (approximately)	250	250
Protection rating	IP40	IP40

### General characteristics

Motor	82 520 0	82 520 4
Gearbox	81 033 0	81 033 0
Maximum permitted continuous rated gearbox output torque for 1 million revolutions of gearbox output shaft Nm	2.0	2.0
Axial load static (daN)	1	1
Radial load static (daN)	10	10
Absorbed power (W)	3.5	3.5
Motor output (W)	0.98	1.12
Maximum temperature rise (°C)	50	50
Ambient temperature (°C)	-5 → +70	-5 → +70
Weight (g)	260	350
Wires length mm (approximately)	250	250
Protection rating	IP40	IP40

## Product adaptations

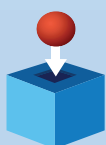

- Special supply voltages
- Special cable lengths
- Special connectors
- Special output shafts
- Special gearbox ratios
- Special gear wheel material
- Special output bearings

## Curves

Torque/speed curves 82 529 0

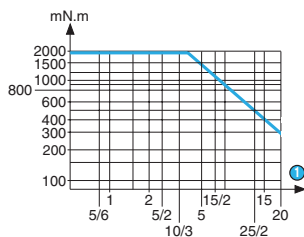

① RPM

Torque/speed curves 82 529 4

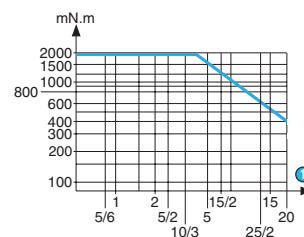

① RPM

To order, see page 13

## Accessories

Voltages/Frequencies	$\mu\text{F}$	V	Code
Capacitors for motor 82 520 0			
230-240 V - 50 Hz	$0.10 \pm 10 \%$	700	26 231 941
115 V - 60 Hz	$0.33 \pm 10 \%$	400	26 231 801
24 V - 50 Hz	$8.2 \pm 10 \%$	70	26 231 711
Capacitors for motor 82 520 4			
230/240 V - 50 Hz	$0.12 \pm 10 \%$	600	26 231 903
115 V - 60 Hz	$0.39 \pm 5 \%$	630	26 231 924
24 V - 50 Hz	$15 \pm 5 \%$	70	26 231 728
24 V - 60 Hz	$12 \pm 5 \%$	63	26 231 145

## Dimensions

82 529 0 - 82 529 4

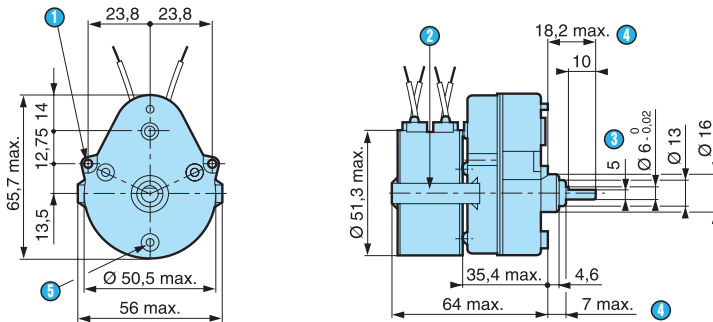

- ① 2 fixing holes  $\text{Ø} 3.2$
- ② Fixing clip
- ③ 5 across flat
- ④ (pushed-in shaft  $\leftarrow$ )
- ⑤ 3 mounting bosses  $\text{Ø} 7.2$  at  $120^\circ$   
on radius= 19.5 - 3 holes M3 depth 4

## Options

Shaft 79 202 573

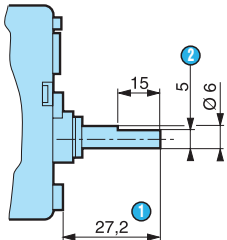

- ① (shaft pushed-in  $\leftarrow$ )
- ② 5 across flat

## Connections

In parallel Motors 82 520 0 - 82 520 4

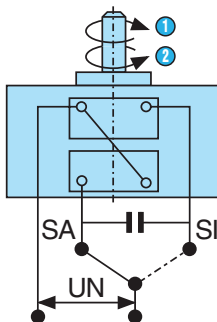

- ① SA : clockwise
- ② SI : anti-clockwise

## Other information

The speed of a motor powered by a 60 Hz supply is 20 % higher than that of a motor powered by a 50 Hz supply.

# Reversible synchronous geared motors

→ 3 Nm 2.7 Watts

- Mechanical strength : 3 Nm
- Constant speed, dependent on supply frequency
- Direction of rotation controlled by dephasing capacitor
- Permanent magnet rotor
- UL, CSA, VDE approved, comply with IEC standards



## Specifications

			2.7 Watts	2.7 Watts
Type			80 513 0	80 513 5
Voltages/Frequencies			230-240 V 50 Hz	230-240 V 50 Hz
Base speed of motor (rpm)			250	500
Output speed (250 RPM)	Output speed (500 RPM)	Ratios (i)		
12	24	20.83	●	●
6	12	41.66	●	●
3	6	83.33	●	●
1.667	3.333	150	●	●
1.333	2.667	187.5	●	●
0.833	1.667	300	●	●
0.667	1.333	375	●	●
0.417	0.833	600	●	●
0.333	0.667	750	●	●
0.208	0.417	1200	●	●
0.111	0.222	2250	●	●
0.104	0.208	2400	●	●
0.069	0.139	3600	●	●
General characteristics				
Motor			82 510 0	82 510 5
Gearbox			81 023 0	81 023 0
Maximum permitted continuous rated gearbox output torque (Nm)			3	3
Axial load static (daN)			2	2
Radial load static (daN)			3	3
Absorbed power (W)			2.7	2.7
Motor output (W)			0.31	0.52
Maximum temperature rise (°C)			55	65
Ambient temperature (°C)			-10 → +75	-5 → +65
Weight (g)			370	370
Wires length mm (approximately)			250	250
Protection rating			IP00	IP00

## Product adaptations

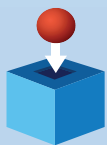

- Special supply voltages
- Special cable lengths
- Special connectors
- Special output shafts
- Special gearbox ratios
- Special gear wheel material
- Special output bearings
- Special mounting plate

## Curves

Torque / speed curves 80 513 0

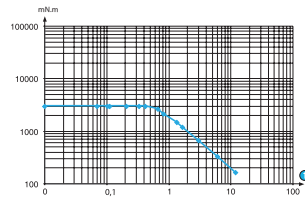

① RPM

Torque / speed curves 80 513 5

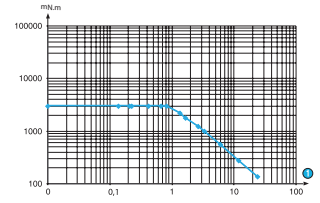

① RPM

## Accessories

Voltages/Frequencies	$\mu\text{F}$	V	Code
Capacitors for motor 82 510 0			
230-240 V - 50 Hz	$0.33 \pm 10\%$	400	26 231 801
115 V - 50/60 Hz	$0.27 \pm 10\%$	250	26 231 851
24 V - 50 Hz	$8.2 \pm 10\%$	70	26 231 711
24 V - 60 Hz	$6.8 \pm 10\%$	63	26 231 708
Capacitors for motor 82 510 5			
230-240 V - 50/60 Hz	$0.39 \pm 10\%$	630	26 231 924
115 V - 50/60 Hz	$0.39 \pm 10\%$	630	26 231 924
24 V - 50/60 Hz	$8.2 \pm 10\%$	70	26 231 711

## Dimensions

80 513 0/5

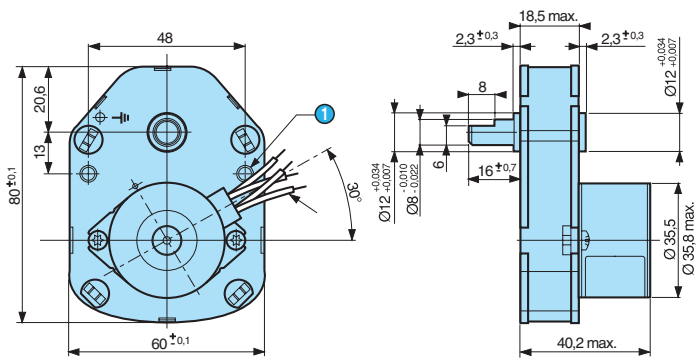

① 2 fixing holes  $\text{Ø } 4.1 \text{ max.}$

## Other information

The speed of a motor powered by a 60 Hz supply is 20 % higher than that of a motor powered by a 50 Hz supply.

# Reversible synchronous geared motors

→ 3 Nm 3.5 Watts

- Mechanical strength : 3 Nm
- Constant speed, dependent on supply frequency
- Direction of rotation controlled by dephasing capacitor
- Permanent magnet rotor
- UL, CSA, VDE approved, comply with IEC standards



## Specifications

		3.5 Watts	3.5 Watts
Type		80 523 0	80 533 0
Voltages/Frequencies		230-240 V 50 Hz	230-240 V 50 Hz
Base speed of motor (rpm)		250	250
Output speed (250 RPM)	Ratios (i)		
12	20.83	●	●
6	41.66	●	●
3	83.33	●	●
1.667	150	●	●
1.333	187.5	●	●
0.833	300	●	●
0.667	375	●	●
0.417	600	●	●
0.333	750	●	●
0.208	1200	●	●
0.111	2250	●	●
0.104	2400	●	●
0.069	3600	●	●
General characteristics			
Motor		82 520 0	82 530 0
Gearbox		81 023 0	81 023 0
Maximum permitted continuous rated gearbox output torque (Nm)		3	3
Axial load static (daN)		2	2
Radial load static (daN)		3	3
Absorbed power (W)		3.5	3.6
Motor output (W)		0.98	1.37
Maximum temperature rise (°C)		55	45
Ambient temperature (°C)		-10 → +75	-10 → +85
Weight (g)		490	620
Wires length mm (approximately)		250	250
Protection rating		IP00	IP00

## Product adaptations

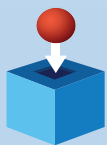

- Special supply voltages
- Special cable lengths
- Special connectors
- Special output shafts
- Special gearbox ratios
- Special gear wheel material
- Special output bearings
- Special mounting plate

## Curves

Torque / speed curves 80 523 0

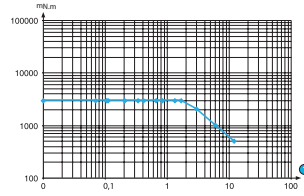

① RPM

Torque / speed curves 80 533 0

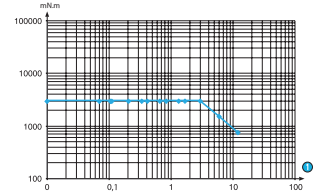

① RPM

## Accessories

Voltages/Frequencies	$\mu\text{F}$	V	Code
<b>Capacitors for motor 82 520 0</b>			
230-240 V - 50 Hz	$0.10 \pm 10 \%$	700	26 231 941
115 V - 60 HZ	$0.33 \pm 10 \%$	400	26 231 801
24 V - 50 Hz	$8.2 \pm 10 \%$	70	26 231 711
<b>Capacitors for motor 82 530 0</b>			
230-240 V - 50 Hz	$0.10 \pm 10 \%$	700	26 231 941
115 V - 50/60 Hz	$0.39 \pm 10 \%$	630	26 231 924
24 V - 50 Hz	$10 \pm 5 \%$	100	26 231 720
24 V - 60 Hz	$6.8 \pm 10 \%$	63	26 231 708

## Dimensions

### 80 523 0

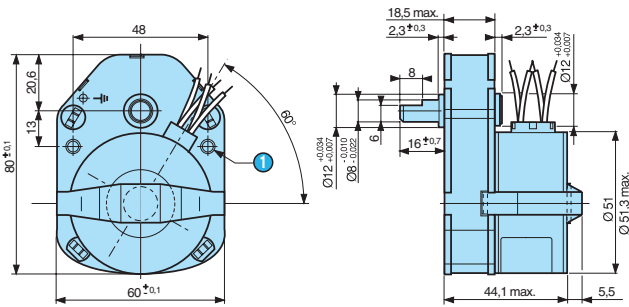

① 2 fixing holes  $\varnothing 4.1$  max.

### 80 533 0

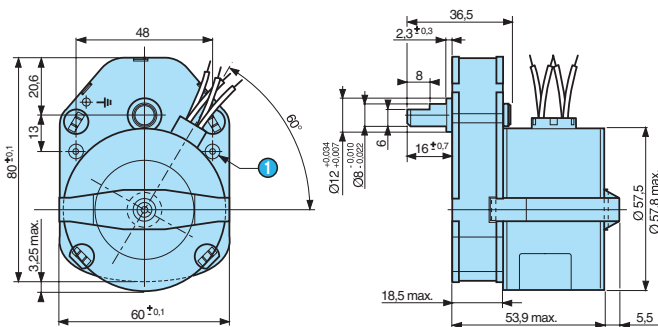

① 2 fixing holes M4 x 11

## Other information

The speed of a motor powered by a 60 Hz supply is 20 % higher than that of a motor powered by a 50 Hz supply.

# Reversible synchronous geared motors

→ 5 Nm 2.7 and 3.5 Watts

- Mechanical strength : 5 Nm
- Constant speed, dependent on supply frequency
- Direction of rotation controlled by dephasing capacitor
- Permanent magnet rotor
- UL, CSA, VDE approved ; comply with IEC standards



## Specifications

			2.7 watts	3.5 Watts
Type			80 517 0	80 527 0
Voltage / Frequency			230-240 V / 50 Hz	230-240 V / 50 Hz
Base speed of motor (rpm)			250	250
<b>Output speed (250 RPM)</b>	<b>Output speed (375 RPM)</b>	<b>Ratios</b>		
20 rpm	30 rpm	12.5	●	80 527 010
10 rpm	15 rpm	25	●	80 527 001
8 rpm	12 rpm	31.25	●	●
6 rpm	9 rpm	41.66	●	80 527 002
4 rpm	10 rpm	62.5	●	80 527 003
3 rpm	4.5 rpm	83.33	●	●
2 rpm	3 rpm	125	●	80 527 005
1 rpm	1.5 rpm	250	●	80 527 006
0.5 rpm	0.75 rpm	500	●	●
0.33 rpm	0.5 rpm	750	●	80 527 008
0.1 rpm	0.15 rpm	2500	●	●
<b>General characteristics</b>				
Motor			82 510 0	82 520 0
Gearbox			81 037 0	81 037 0
Maximum permitted continuous rated gearbox output torque for 1 million revolutions of gearbox output shaft (Nm)			5	5
Axial load static (daN)			2	2
Radial load static (daN)			3	3
Absorbed power (W)			2.7	3.5
Motors output (W)			0.31	0.98
Maximum temperature rise (°C)			50	50
Ambient temperature (°C)			-10 → +70	-10 → +70
Weight (g)			410	530
Wires length mm (approximately)			250	250
Protection rating			IP40	IP40

## Product adaptations

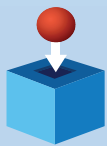

- Special supply voltages
- Special cable lengths
- Special connectors
- Special output shafts
- Special gearbox ratios
- Special gear wheel material
- Special output bearings

## Curves

Torque/speed curves 80 517 0

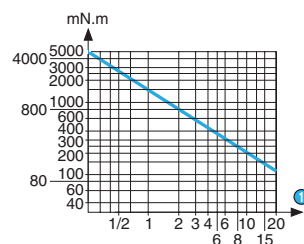

① RPM

Torque/speed curves 80 527 0

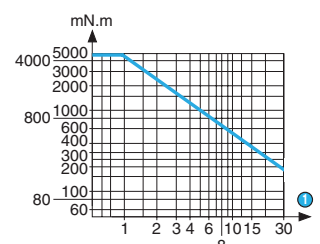

① RPM

To order, see page 13

## Accessories

Voltages/Frequencies	$\mu\text{F}$	V	Code
Capacitors for motor 82 510 0			
230-240 V - 50 Hz	$0.33 \pm 10 \%$	400	26 231 801
115 V - 50/60 Hz	$0.27 \pm 10 \%$	250	26 231 851
24 V - 50 Hz	$8.2 \pm 10 \%$	70	26 231 711
24 V - 60 Hz	$6.8 \pm 10 \%$	63	26 231 708
Capacitors for motor 82 520 0			
230-240 V - 50 Hz	$0.10 \pm 10 \%$	700	26 231 941
115 V - 60 Hz	$0.33 \pm 10 \%$	400	26 231 801
24 V - 50 Hz	$8.2 \pm 10 \%$	63	26 231 711

## Dimensions

### 80 517 0 - 80 527 0

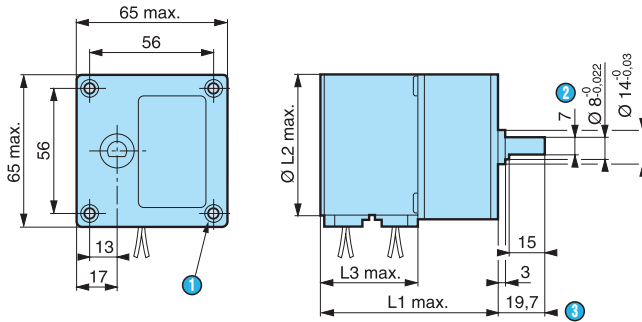

- ① 4 holes M4 depth 12
- ② 7 across flat
- ③ (pushed-in shaft ←)

80 517 0 L1 = 55.3 mm Ø L2 = 35.8 mm L3 = 21.7 mm  
 80 527 0 L1 = 59.2 mm Ø L2 = 51.3 mm L3 = 25.6 mm

## Options

### Shaft 79 206 478

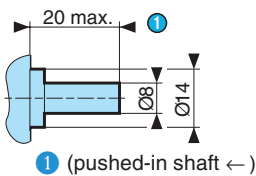

- ① (pushed-in shaft ←)

## Connections

### In parallel Motors 82 510 0 - 82 520 0

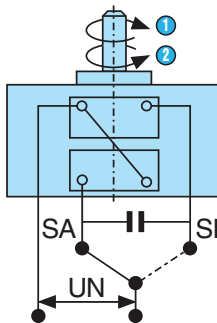

- ① SA : clockwise
- ② SI : anti-clockwise

### In series Motor 82 510 0 only 230 V - 240 V 50 Hz version

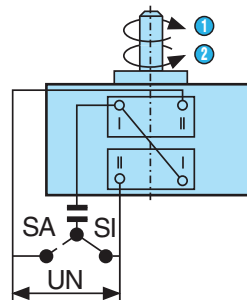

- ① SA : clockwise
- ② SI : anti-clockwise

## Other information

The speed of a motor powered by a 60 Hz supply is 20 % higher than that of a motor powered by a 50 Hz supply.

# Reversible synchronous geared motors

→ 5 Nm 3.5 and 7.2 Watts

- Mechanical strength : 5 Nm
- Constant speed, dependent on supply frequency
- Direction of rotation controlled by dephasing capacitor
- Permanent magnet rotor
- UL, CSA, VDE approved ; comply with IEC standards



## Specifications

Type  
Voltage / Frequency  
Base speed of motor (rpm)

**3.5 Watts**  
80 527 4  
230-240 V / 50 Hz  
375

**7.2 Watts**  
80 547 0  
230-240 V / 50 Hz  
250

Output speed (250 RPM)	Output speed (375 RPM)	Ratios	3.5 Watts	7.2 Watts
20 rpm	30 rpm	12.5	●	80 547 024
10 rpm	15 rpm	25	●	80 547 015
8 rpm	12 rpm	31.25	●	●
6 rpm	9 rpm	41.66	●	80 547 016
4 rpm	10 rpm	62.5	●	80 547 017
3 rpm	4.5 rpm	83.33	●	80 547 018
2 rpm	3 rpm	125	●	80 547 019
1 rpm	1.5 rpm	250	●	80 547 020
0.5 rpm	0.75 rpm	500	●	80 547 021
0.33 rpm	0.5 rpm	750	●	●
0.1 rpm	0.15 rpm	2500	●	●

### General characteristics

Motor	82 520 4	82 540 0
Gearbox	81 037 0	81 037 0
Maximum permitted continuous rated gearbox output torque for 1 million revolutions of gearbox output shaft (Nm)	5	5
Axial load static (daN)	2	2
Radial load static (daN)	3	3
Absorbed power (W)	3.5	7.2
Motors output (W)	1.12	2.65
Maximum temperature rise (°C)	50	55
Ambient temperature (°C)	-10 → +70	-10 → +70
Weight (g)	530	860
Wires length mm (approximately)	250	250
Protection rating	IP40	IP40

## Product adaptations

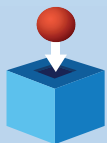

- Special supply voltages
- Special cable lengths
- Special connectors
- Special output shafts
- Special gearbox ratios
- Special gear wheel material
- Special output bearings

## Curves

Torque/speed curves 80 527 4

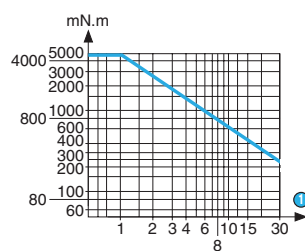

① RPM

Torque/speed curves 80 547 0

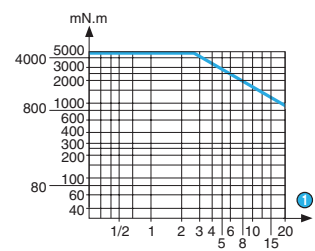

① RPM

To order, see page 13

## Accessories

Voltages/Frequencies	$\mu\text{F}$	V	Code
Capacitors for motors 82 520 4			
230/240 V - 50 Hz	$0.12 \pm 10 \%$	600	26 231 903
115 V - 60 Hz	$0.39 \pm 5 \%$	630	26 231 924
24 V - 50 Hz	$15 \pm 5 \%$	70	26 231 728
24 V - 60 Hz	$12 \pm 5 \%$	63	26 231 145
Capacitors for motor 82 540 0			
230-240 V 50 Hz	$0.22 \pm 5 \%$	630	26 231 909
115 V - 60 Hz	$0.56 \pm 5 \%$	400	26 231 822
24 V - 50 Hz	$22 \pm 10 \%$	63	26 231 703
24 V - 60 Hz	$15 \pm 5 \%$	70	26 231 728

## Dimensions

80 527 4 - 80 547 0

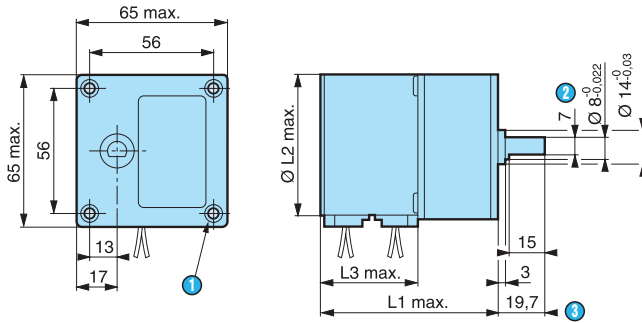

- ① 4 holes M4 depth 12
- ② 7 acroos flat
- ③ (pushed-in shaft ←)

80 527 4 L1 = 59.2 mm Ø L2 = 51.3 mm L3 = 25.6 mm  
 80 547 0 L1 = 76.6 mm Ø L2 = 65.3 mm L3 = 43 mm

## Options

Shaft 79 206 478

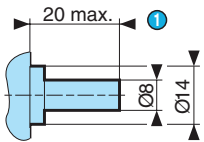

- ① (pushed-in ←)

## Connections

In parallel

Motors 82 520 4 - 82 540 0

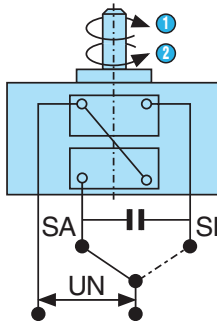

- ① SA : clockwise
- ② SI : anti-clockwise

## Other information

The speed of a motor powered by a 60 Hz supply is 20 % higher than that of a motor powered by a 50 Hz supply.

