









Pressure regulator, Series AS1-RGS

- G 1/4
- Air supply left
- Qn = 1000 l/min
- Standard pressure regulator
- Activation Manual



Parts	Pressure regulator
Mounting orientation	Any
Working pressure min./max.	See table below
Ambient temperature min./max.	-10 ... 50 °C
Medium temperature min./max.	-10 ... 50 °C
Medium	Compressed air Neutral gases
Regulator type	Diaphragm-type pressure regulator Can be assembled into blocks
Regulator function	with relieving air exhaust
Adjustment range min./max.	See table below
Activation	Manual
Weight	See table below

Technical data

Part No.			Port	Flow	Working pressure min./max.	Adjustment range min./max.
				Qn		
R412014627			G 1/4	1000 l/min	0,2 ... 12 bar	0,2 ... 4 bar
R412014628			G 1/4	1000 l/min	0,5 ... 12 bar	0,5 ... 8 bar
R412014629			G 1/4	1000 l/min	0,5 ... 12 bar	0,5 ... 10 bar
R412014633		—	G 1/4	1000 l/min	0,2 ... 12 bar	0,2 ... 4 bar
R412014634		—	G 1/4	1000 l/min	0,5 ... 12 bar	0,5 ... 8 bar
R412014635		—	G 1/4	1000 l/min	0,5 ... 12 bar	0,5 ... 10 bar

Part No.	Max. pressure gauge Ø in blocked state	Pressure gauge	Weight	Fig.
R412014627	40 mm	With integrated pressure gauge	0,209 kg	Fig. 1
R412014628	40 mm	With integrated pressure gauge	0,209 kg	Fig. 1
R412014629	40 mm	With integrated pressure gauge	0,209 kg	Fig. 1
R412014633	40 mm	-	0,206 kg	Fig. 2
R412014634	40 mm	-	0,206 kg	Fig. 2
R412014635	40 mm	-	0,206 kg	Fig. 2

Part No.	
R412014627	-
R412014628	-
R412014629	-
R412014633	1)
R412014634	1)
R412014635	1)

Nominal flow Qn with secondary pressure p2 = 6 bar at Δp = 1 bar

1) Order pressure gauge separately

Technical information

The pressure dew point must be at least 15 °C under ambient and medium temperature and may not exceed 3 °C .
 Relieving exhaust (≤ 0.3 bar over set pressure).
 With rear exhaust (> 3 bar).

Technical information

Material	
Housing	Polyamide
Front plate	Acrylonitrile butadiene styrene
Seals	Acrylonitrile butadiene rubber

Dimensions

Dimensions, Fig. 1

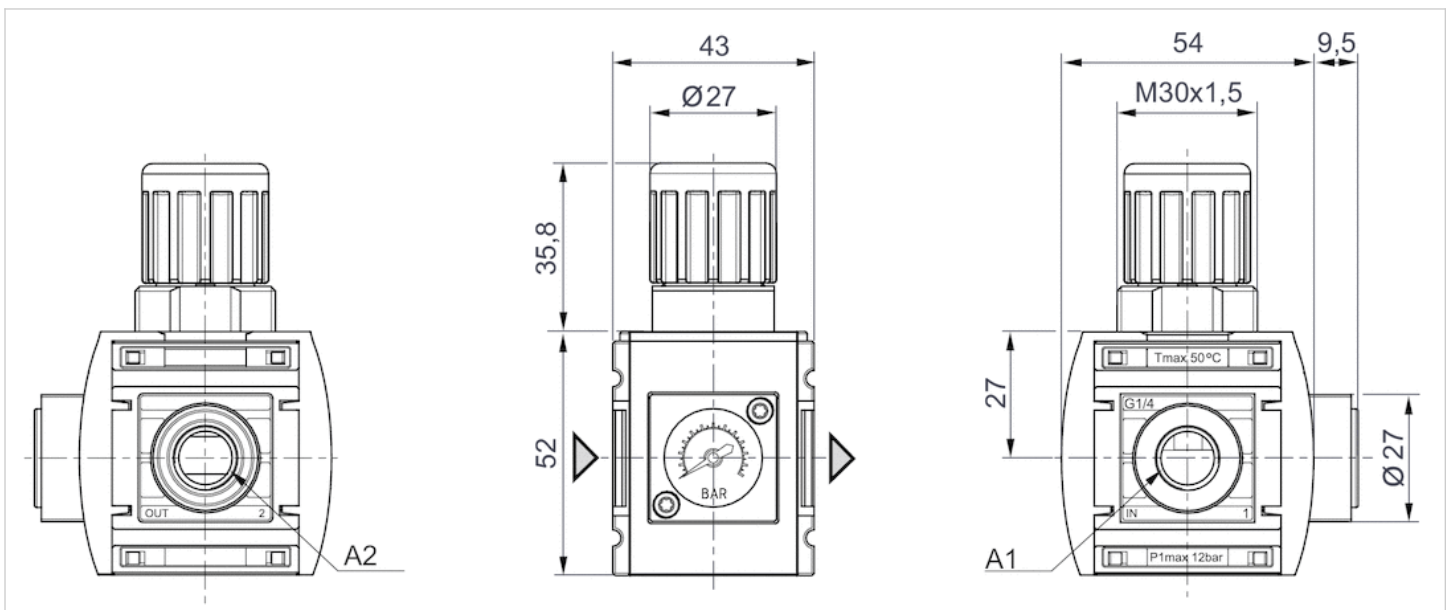

A1 = input
 A2 = output

Flow rate characteristic

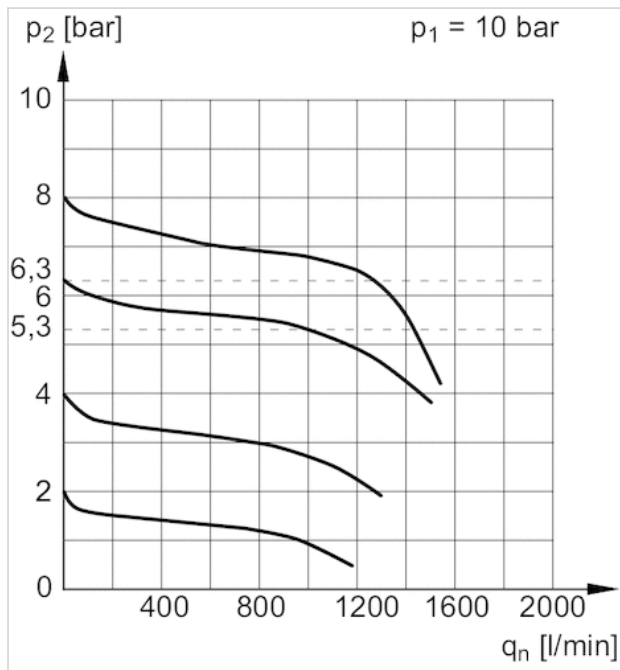

p_1 = working pressure
 p_2 = secondary pressure
 q_n = nominal flow

Accessories overview

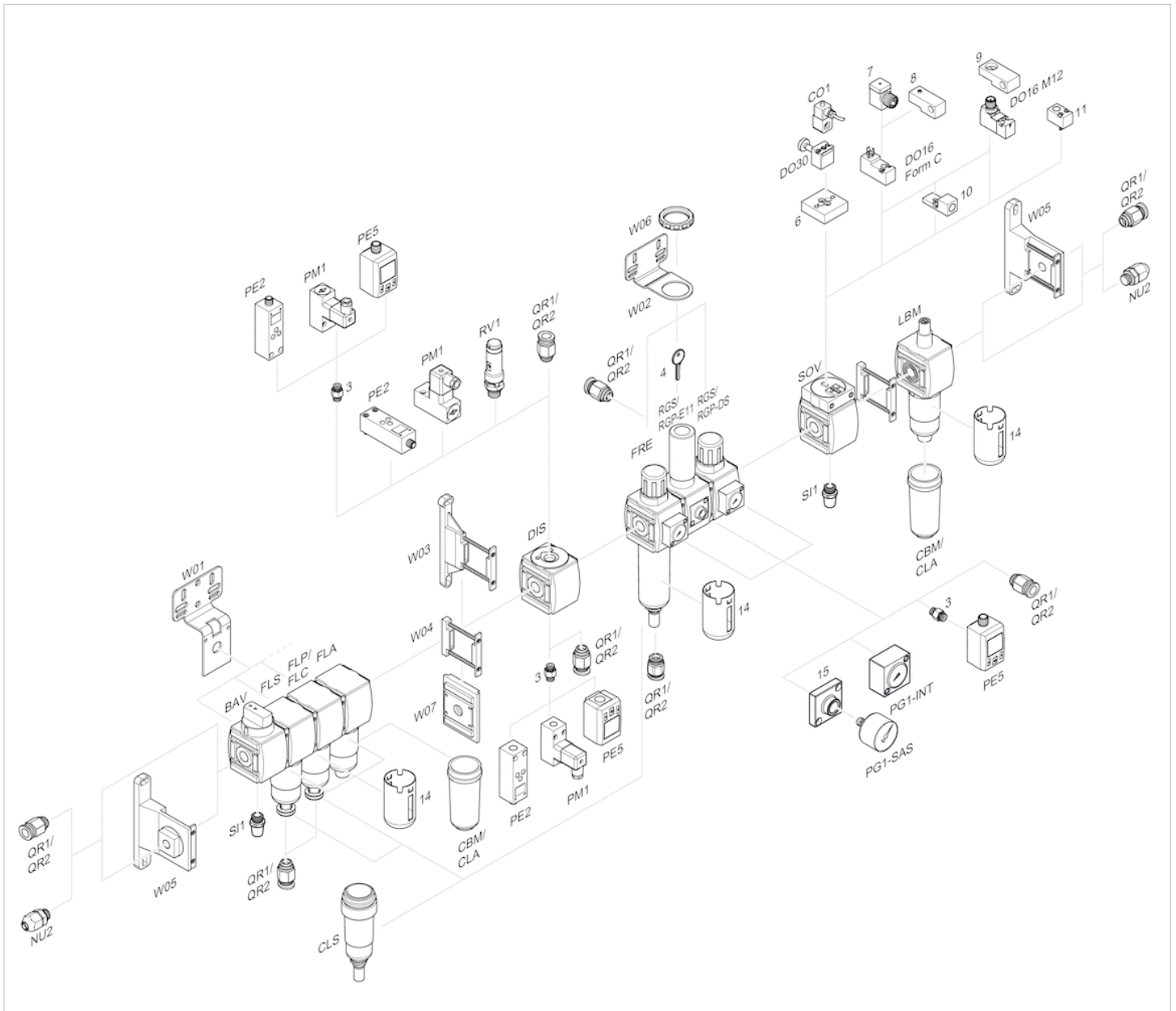

- 3 = Double nipple
- 4 = Key for E11 locking
- 6 = Transition plate DO30
- 7 = Adapter, Series CON-VP
- 8 = Mounting aid DO16, form C
- 9 = Mounting aid DO16, M12
- 10 = Adapter for external pilot air
- 11 = Adapter pneumatic operation
- 14 = Protective guard
- 15 = Transition plate for assembling a pressure gauge with connection thread G 1/8