

PLANETARY GEAR

- REDUCTORES PLANETARIOS: combinables con la serie 269. Ver sección especial en catálogo.
- PLANETARY GEARS: combinable with 269 series. See special section in catalogue.
- REDUCTEURS PLANETAIRES: combinables avec la série 269. Consultez section spécial du catalogue.
- PLANETENGETRIEBE: Mit der Reihe 269 kombinierbar. Sehen Sie Sonderabschnitt im Katalog.

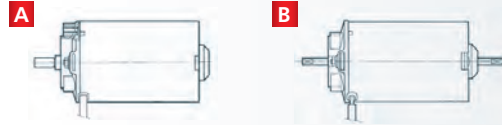

REFERENCIA REFERENCE NUMBER REFERENZNUMMERN	TENSION NOMINAL NOMINAL VOLTAGE TENSION NOMINALE NENNSPANNUNG	PAR NOMINAL NOMINAL TORQUE COUPLE NOMINAL DREHMOMENT NOMINAL	VELOCIDAD NOMINAL NOMINAL SPEED VITESSE NOMINALE GESCHWINDIGKEIT NOMINAL	CORRIENTE NOMINAL NOMINAL CURRENT COURANT NOMINAL NOMINALSTROM	PAR DE ARRANQUE STARTING TORQUE COUPLE DE DÉMARRAGE ANZUGSDREHMOMENT	CORRIENTE DE ARRANQUE STARTING CURRENT COURANT DE DÉMARRAGE ANLAUFSTROM	EJE SHAFT ARBRE WELLE	CONEXIONES CONNECTIONS CONNEXIONS ANSCHLUSSART	ESQUEMA ELÉCTRICO WIRING DIAGRAM SCHEMA ÉLECTRIQUE SCHALTBILD	PESO APROXIMADO APPROXIMATE WEIGHT POIDS APPROXIMATIF GEWICHT (ca.)	GRADO DE ESTANQUEIDAD WATERTIGHTNESS ÉTANCHÉITÉ FEUCHTIGKEITSSCHUTZKLASSE	DISEÑO: A,B DESIGN: A,B DESSIN: A,B ABBILDUNG: A,B	CURVA CURVE COURBE KURVE
	Un (V)	Mn (N.m./lbf.in)	Pn (r.p.m.)	In (A)	Ma (N.m./lbf.in)	Ia (A)				P (kg/lb.t)	IP		
269.4102.20.04	12	0.50 / 4.42	3000	20	4 / 35.4	140	E20	C22	EE2	3.8 / 10.18	IP53	A	52
269.4102.30.04	24	0.75 / 6.63	3000	15	4 / 35.4	120	E20	C22	EE2	3.8 / 10.18	IP53	A	53
269.4103.20.04	12	0.50 / 4.42	3000	20	4 / 35.4	140	E21	C23	EE2	3.8 / 10.18	IP53	A	52
269.4103.30.04	24	0.75 / 6.63	3000	15	4 / 35.4	120	E21	C23	EE2	3.8 / 10.18	IP53	A	53
269.4104.20.04	12	0.80 / 7.08	1800	20	4 / 35.4	100	E48	C24	EE2	3.8 / 10.18	IP53	A	54
269.4104.30.04	24	0.80 / 7.08	1800	10	4 / 35.4	50	E48	C24	EE2	3.8 / 10.18	IP53	A	54
269.4106.20.04	12	0.80 / 7.08	1800	20	4 / 35.4	100	E21	C23	EE2	3.8 / 10.18	IP53	A	54
269.4106.30.04	24	0.80 / 7.08	1800	10	4 / 35.4	50	E21	C23	EE2	3.8 / 10.18	IP53	A	54
269.4107.30.04E	24	0.75 / 6.63	3000	15	4 / 35.4	120	E48/E11	C22	F2	3.8 / 10.18	IP40	B	53
269.4108.20.04E	12	0.80 / 7.08	1800	20	4 / 35.4	100	E48/E11	C24	F2	3.8 / 10.18	IP40	B	54
269.4113.30.04	24	0.50 / 4.42	675	2.25	2.7 / 23.8	12	E48	C24	EE2	3.8 / 10.18	IP53	A	55

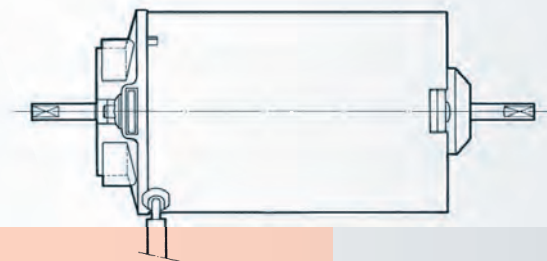
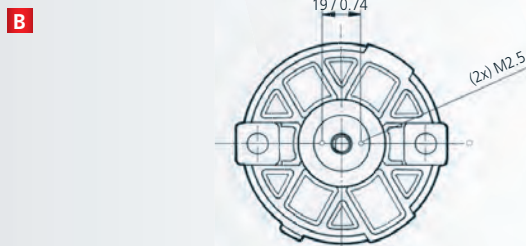
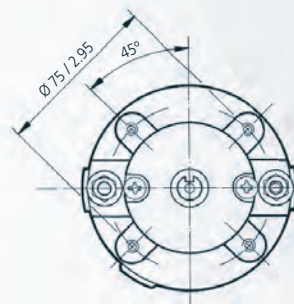
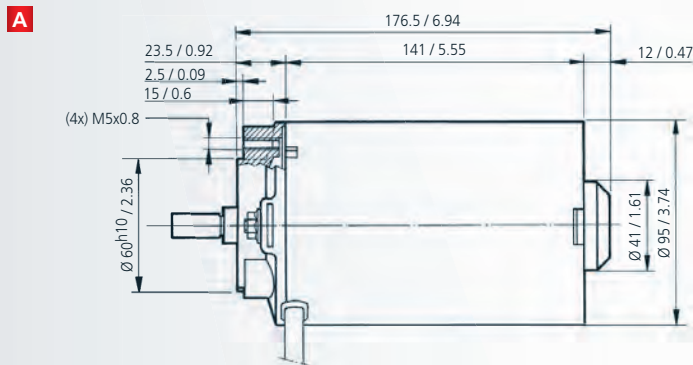

mm / inch

EJE SHAFT ARBRE WELLE

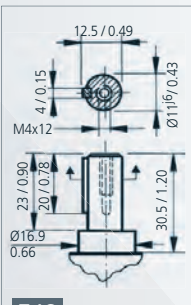
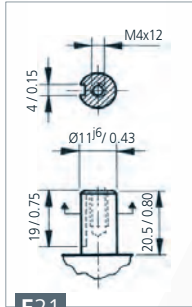
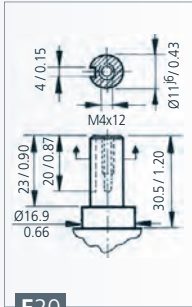
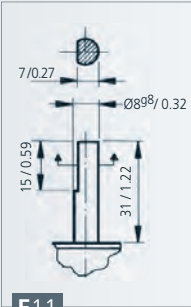

CURVAS CURVES COURBES KURVEN

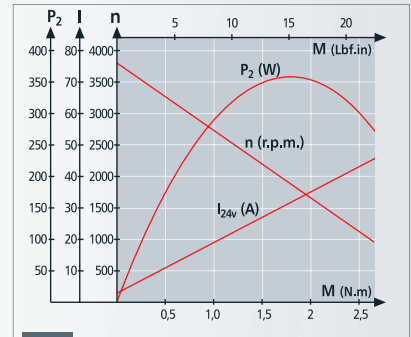
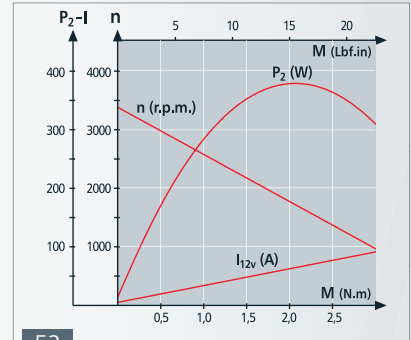

CONEXIONES CONNECTIONS CONNEXIONS ANSCHLUSSART

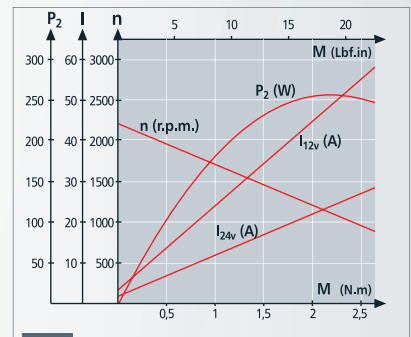
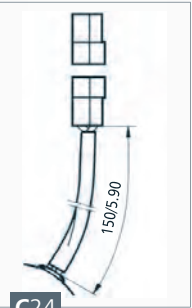
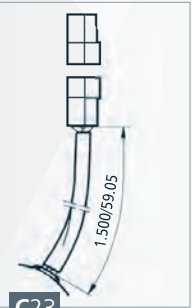
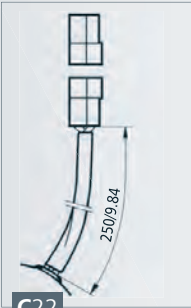

ESQUEMA ELÉCTRICO WIRING DIAGRAM SCHEMA ÉLECTRIQUE SCHALTBILD

