



QL300 / QL500 Quick Link ID-NET™ Connectors

DESCRIPTION

The QL series ID-NET™ connectors provide a fast and efficient way to cable an ID-NET™ network using standard cables. The QL300/500s are typically Master ID-NET™ connectors designed to be used with the QL100/150/200s ID-NET™ Slave connectors.

The QL300 is a passive connection module which can be used in Standalone or ID-NET™ Master Multidata, Slave Multidata or Master Synchronized layouts. It provides separate ports for Power Supply, External Trigger, Digital I/O and Communication. Host communication is provided through connectivity to the reader Main serial interface (RS232/485) or Aux RS232 serial interface.

ID-NET™ network and power supply signals are sent out to the next connected device by means of a dedicated port, however input power is not received from the network. Therefore each QL300 must be powered separately.

The QL500 is an active connection module which can be used in Standalone or ID-NET™ Master Multidata, or Master Synchronized layouts. It provides separate ports for Power Supply, External Trigger, Digital I/O and Communication. Host communication is provided through the integrated Ethernet module which connects internally to the reader's Main serial interface. Reader Aux RS232 serial interface is also provided. ID-NET™ network and power supply signals are sent out to the next connected device by means of a dedicated port, however there is no network input connector and therefore it cannot be used as an ID-NET™ Slave.

The QL series are compatible with the following readers:

DS2100N	DS4800	Matrix 400™
DS2400N		Matrix 200™



QL300



QL500

CONNECTIONS

ID-NET Out M12 5P Female (A-coded)	
Pin	Function
1	Shield
2	Vdc
3	GND
4	ID+
5	ID-

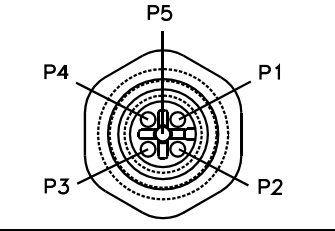

QL300 only (ID-NET In) M12 5P Male (A-coded)	
Pin	Function
1	Shield
2	nc
3	GND
4	ID+
5	ID-

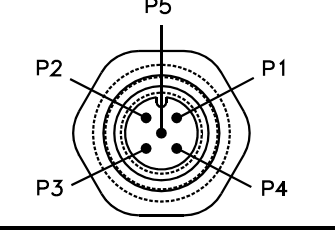

QL500 only (Ethernet) RJ45 8P Female	
Pin	Function
1	TX+
2	TX-
3	RX+
6	RX-
4, 5, 7, 8	nc

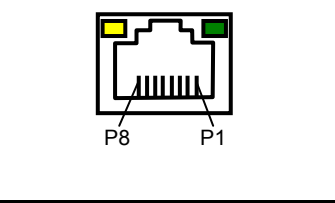

OVERALL DIMENSIONS

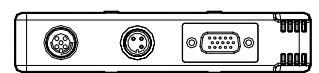
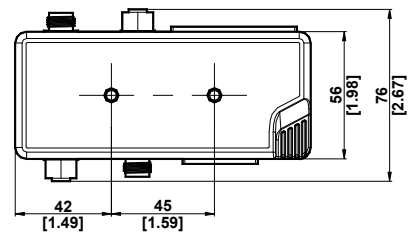
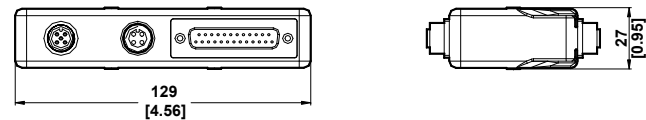

QL300

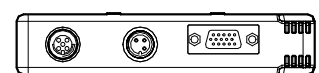
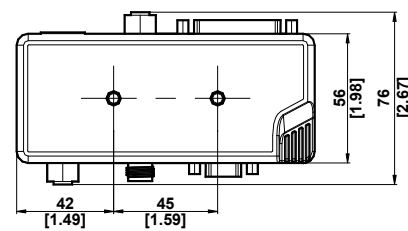
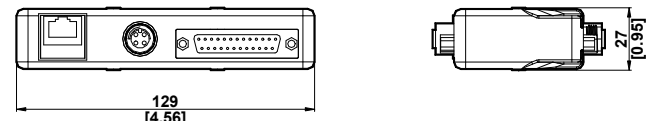

QL500

Power M12 3P Male (B-coded)	
Pin	Function
1	Earth
2	Vdc
3	GND

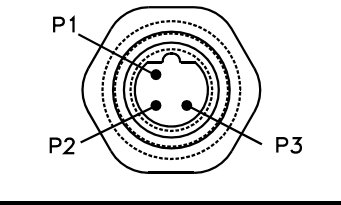

Trigger M12 4P Female (A-coded)	
Pin	Function
1	+V
2	nc
3	-V
4	I1+

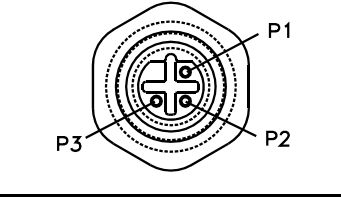

MOUNTING

There are two self-threading screws provided for mounting the QLs to various wooden or plastic surfaces. Mounting to other surfaces such as concrete walls or metallic panels requires user-supplied parts (screws, screw anchors, nuts, etc). Keep in mind that the connected reader must have its Chassis grounded to Earth, see paragraph "Grounding".

QLs can also be mounted to a Bosch Frame using the BA200 mounting accessory.

The distance between mounting bushings is given in the overall dimension diagram for each QL.

NOTE  IP65 protection is provided when the cables (or QLs) are properly mated.

GROUNDING

There are two general rules to follow regarding network grounding:

- 1) The network Shield must only be connected to Earth ground at one point (the Master).

When using isolated power supplies, Earth grounding can be accomplished through the CAB-PW-EXT accessory cable and the BA400 or QL300/500 Power connector.

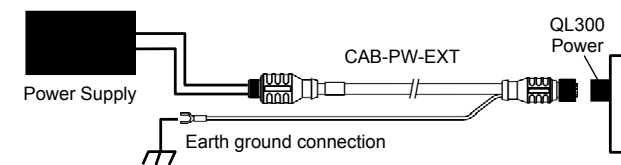

- 2) All reader Chassis must be connected to Earth ground.

All the readers in the network must have their Chassis connected to Earth ground either by: mounting to conductive metal brackets or frames which are connected to Earth ground; or through the CBX or SC4000; or through the QL bushing.

In the case of grounding through the CBX or SC4000, connect the Earth signal to a good earth ground and set the internal Chassis jumper to Earth.

In the case of grounding through the QL bushing, connect a flying lead from the mounting bushing to an Earth ground. The mounting bushing is internally connected to the reader Chassis.

Reader 25P D-Sub Female		Pin	Function
1, shell, both bushings	Reader Chassis		
2	TXM	14	nc
3	RXM	15	nc
4	RTSM *	16	nc
5	CTSM *	17	nc
6	I2A	18	I1A
7	GND	19	GND
8	O1+	20	RXA
9	nc	21	TXA
10	I2B	22	O1-
11	O2+	23	ID+
12	O2-	24	ID-
13	Vdc	25	GND

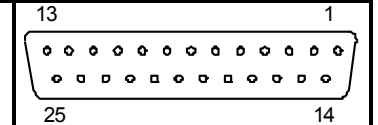

* pins 4 and 5 are nc for QL500.

I/O Port 15P HD D-Sub Female		Pin	Function
1	O1+	9	I2A
2	TXA	10	O2-
3	RXA	11	I2B
4	RXM *	12	TXM *
5	CTSM *	13	GND
6	O1-	14	SGND
7	Vdc	15	RTSM *
8	O2+		

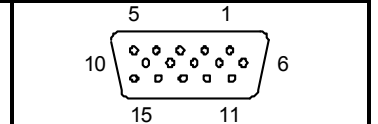

* pins 4, 5, 12 and 15 are nc for QL500.

CAUTION  Do not connect GND and SGND to different (external) ground references. GND and SGND are internally connected through filtering circuitry which can be permanently damaged if subjected to voltage drops over 0.8 Vdc.

ACCESSORIES

Description	Part Number	Connection
Cables		
CAB-PW-EXT M12 POWER EXTENSION CABLE	93A051381	Power
CBL-1480-01 THIN M12/5P MALE/FEMALE 1M	970101021	ID-NET Out/In
CBL-1480-02 THIN M12/5P MALE/FEMALE 2M	970101022	
Terminators		
CBL-1490 TERM. RESIST. THIN M12/5P/MALE	970101069	ID-NET Out
CBL-1496 TERM. RESIST. THIN M12/5P/FEMALE	970101082	ID-NET In
Field Mountable Connectors		
FMC400 M12 3P F. CONN. POWER	93ACC1884	Power
Mounting		
BA200 Bosch Adaptors	93ACC1822	

The FMC accessory connectors can be used to make custom External Power and Service cables in case the standard cables don't satisfy the application requirements.

TECHNICAL SPECIFICATIONS

ELECTRICAL FEATURES	QL300	QL500
Supply Voltage	10 to 30 Vdc (see Voltage Drop below)	
Consumption	-	210 mA - 70 mA
Maximum Distributed Current Allowed see related reading device manual for consumption	4 A	
Inputs	see relative reader Reference Manual	
Outputs	see relative reader Reference Manual	
PHYSICAL FEATURES		
Mechanical Dimensions	129 x 76 x 27 mm (5.1 x 3 x 1.1 in.)	
Weight	312 g. (11 oz.)	309 (10.9 oz.)
ENVIRONMENTAL FEATURES		
Operating Temperature	0° to 50 °C (+32° to 122 °F)	
Storage Temperature	-20° to 70 °C (-4° to 158 °F)	
Humidity max.	90% non condensing	
Vibration Resistance EN 60068-2-6 2 hours on each axis	14 mm @ 2 to 10 Hz 1.5 mm @ 13 to 55 Hz 2 g @ 70 to 200 Hz	
Shock Resistance EN 60068-2-27	30 g; 11 ms; 3 shocks on each axis	
Protection Class EN 60529	IP65 (when IP protection caps or IP cables and reading device are correctly connected)	IP40

The features given are typical at a 25 °C ambient temperature (if not otherwise indicated).

VOLTAGE DROP AND MAX DISTRIBUTED CURRENT CALCULATIONS

For correct network management, the maximum number of readers which can propagate power through the QLs must be calculated so that max distributed current is not exceeded and so voltage drop doesn't affect reader functioning. This is done according to the following formula:

$$\text{Voltage Drop} = (\text{Max Reader Current} \times \text{Number of readers}) \times (\text{Resistance per Meter per wire} \times \text{Cable length in Meters})$$

* the resistance calculation must include both wires (Vdc and GND).

Example:

An ID-NET™ network is composed of 4 DS2100N readers. Three 2 meter ThinNet cables are used to connect the readers, which have Cable Resistance = 0.058 Ohms per meter per wire. The network power is 24 Vdc.

$$(0.2083 \text{ A} \times 4 \text{ readers}) \times [(0.058 \times 2) \times 6 \text{ meters}] = 0.58 \text{ Vdc voltage drop}$$

$$24 \text{ Vdc} - 0.58 = 23.42 \text{ Vdc at reader number 4 (worst case)}$$

Integrate a sufficient number of QL200s to resupply network power.

TYPICAL LAYOUTS

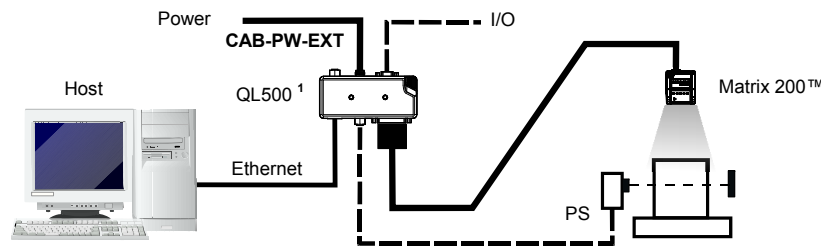

Point to Point - Matrix 200™ with QL500 (Ethernet to Host)

¹ The reader must first be configured for Ethernet communication. This is done by connecting to the reader through the RS232 Aux port available on the QL500 I/O Port and running the software configuration program.

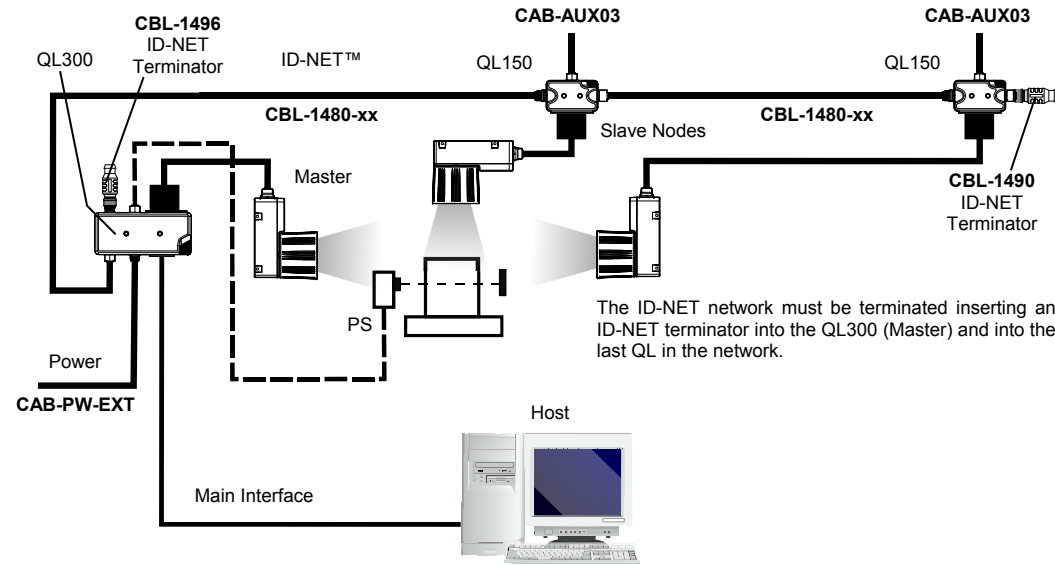

ID-NET™ Synchronized Network - Matrix 400™ Master with QL300 + Matrix 400™ Slaves with QL150

TRIGGER

In order to allow direct trigger cabling between the photocell and the QL300/500 using standard M12 A-coded one-to-one cables, the trigger signal has been internally wired to manage PNP type photocells. The external trigger therefore **must be connected as shown in the diagram below**.

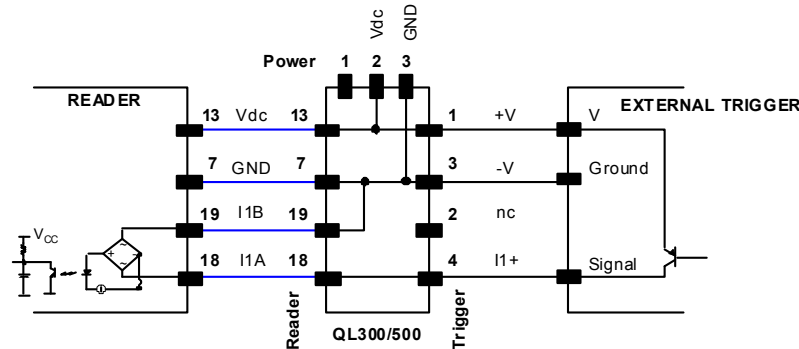

The electrical features of both inputs and outputs are given in the relative reader Reference Manual.

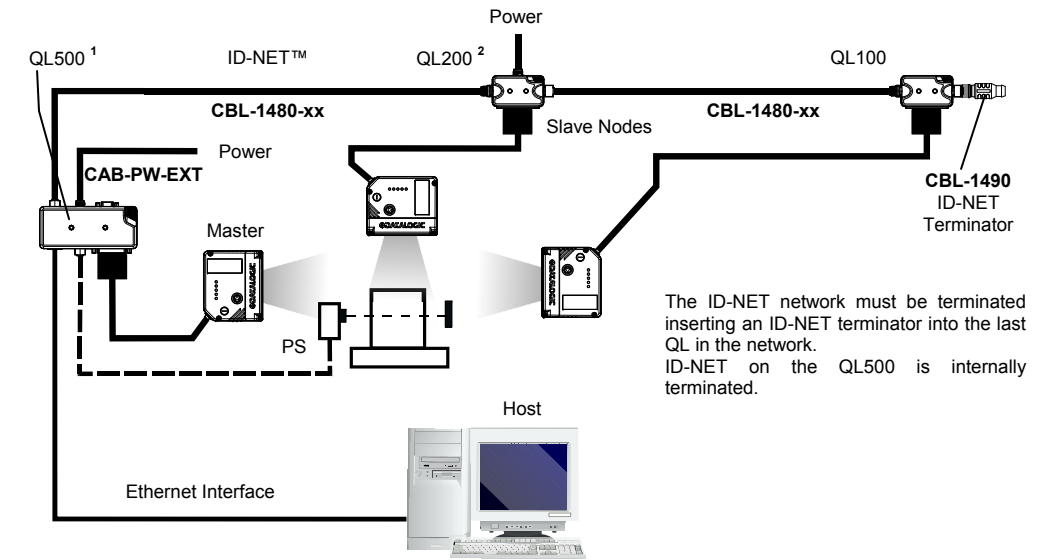

ID-NET™ Synchronized Network - DS4800 Master with QL500 + DS4800 Slaves with QL200 and QL100

¹ The reader must first be configured for Ethernet communication. This is done by connecting to the reader through the RS232 Aux port available on the QL500 I/O Port and running the software configuration program.

² The above diagram is an example showing layout connections and is not intended to represent power limits, which instead, depend on each specific application. See "Voltage Drop and Max Distributed Current Calculations".

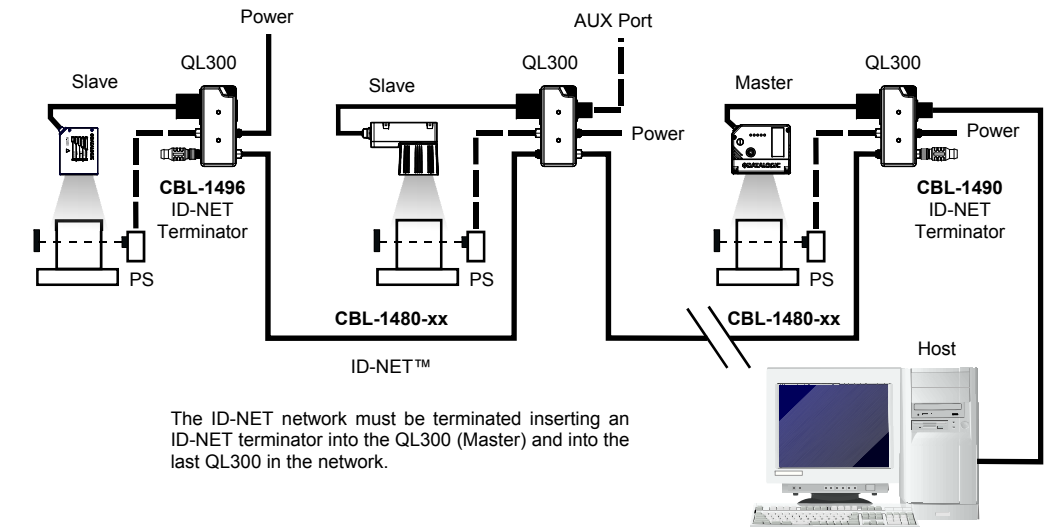

ID-NET™ Multidata Network - DS4800 Master with QL300 + Mixed Reader Slaves with QL300s

COMPLIANCE

FCC Compliance

Modifications or changes to this equipment without the expressed written approval of Datalogic could void the authority to use the equipment.

This device complies with PART 15 of the FCC Rules. Operation is subject to the following two conditions: (1) This device may not cause harmful interference, and (2) this device must accept any interference received, including interference which may cause undesired operation.

This equipment has been tested and found to comply with the limits for a Class A digital device, pursuant to part 15 of the FCC Rules. These limits are designed to provide reasonable protection against harmful interference when the equipment is operated in a commercial environment. This equipment generates, uses, and can radiate radio frequency energy and, if not installed and used in accordance with the instruction manual, may cause harmful interference to radio communications. Operation of this equipment in a residential area is likely to cause harmful interference in which case the user will be required to correct the interference at his own expense.

CE Compliance

Warning:

This is a Class A product. In a domestic environment this product may cause radio interference in which case the user may be required to take adequate measures.

Power Supply

This product is intended to be installed by Qualified Personnel only.

This accessory device is intended to be supplied by a UL Listed or CSA Certified Power Unit with «Class 2» or LPS power source.