

PISA-M

PISA-M-4ADJ

ECB 4x1-8A Adjustable current

- 4 channels (4x1-8A)
- Only 22.5mm width
- Joint or individual alarm
- Fast or slow characterization



PRODUCT DESCRIPTION

- 4 channels
- Only 22.5mm wide
- Each channel can be adjusted to: 1/2/3/4/6/8 A (max 20 A total)
- You can choose fast or slow characteristics (e.g. slow for equipment that requires starting current)
- Press connection
- Local or remote recovery

The courses can be turned on and off using the 4 buttons on the front. The track is on if it lights up green and off if it glows red with a steady light.

The 4 courses start at about 100 ms intervals.

The factory settings are that all channels are connected with the setting 1A and fast characteristic.

If a channel is tripped, the respective LED flashes red once for overload or short circuit and red twice for (a) the total overload protection of 20 A for sec is activated or (b) the power supply protection mode is activated. For more information, see the User's Guide, Section 9. To reset the course, press and hold the respective course button for 1 sec.

To check what the different channels are set to in the Amp level:

Press buttons 1 and 4 at the same time for a short time (50 ms).

LED 1 will then flash green quickly for the number of Amps set (once for 1 A, twice for 2 A, etc.).

To change the different Amp levels on the different channels: (Max. 20 A total)

Press buttons 1 and 4 at the same time for 1 sec (all channels will be orange)

Short press button 1 (50 ms), then press within 4 sec. the number of times corresponding to the desired gain level, e.g. 3 times corresponds to 3 A. Then it flashes quickly 3 times (green) (in 2 sequences) Then press button 1 for 1 sec. to save. It then shines with a solid green light. Repeat for channels 2-3 and 4. To exit the programming mode, press buttons 1 and 4 at the same time for a short time (50 ms).

To see and change whether the fuse is set to fast or slow characterization:

Press buttons 1 and 3 at the same time for a short time (50 ms)

LEDs 1-4 will then flash green at a fast speed for fast or slow characteristics (daytime running lights)

Press buttons 1 and 3 again at the same time for a short time (50 ms) (within 4 sec). This changes the characteristic.

This is automatically saved.

If you do not press any button within 10 seconds, you will automatically exit programming mode.

Clear recovery

If a circuit has tripped, you can apply a voltage of 10-30 V DC (under 1 sec) to terminals 3.3 (+) and 3.4 (-), once the cause has been found and the fault has

been fixed. Other channels are not affected, regardless of whether they are connected or disconnected.

Alarm contact From the factory, it is delivered as a trippy alarm. See the 4 different alarm options below. For more information, see Section 12 of the User's Guide.

You can connect multiple PISA-M modules in parallel to create multiple courses. Each (+) on the PISA-M module must be connected directly to the power supply.

We recommend a free space of 40 mm above and 30 mm below. 0 mm on the sides, 15 mm if the component on the side emits heat (e.g. power supply).

Properties: (otherwise see section 6 of the data sheet)

Sensitivity: < 2ms - 0.22 sec in case of short circuit and 1.5 x In.

Slow: < 10 ms - 1.1 sec in case of short circuit and 1.5 x In.

TECHNICAL DATA

OUTPUT DATA

Output current max	20 A
Voltage drop over semiconductor	130 mV
Efficiency	98 %

DIMENSIONS

Width	23 mm
Depth	98 mm
Height	104 mm

CONNECTION DATA

IP class	IP20
----------	------

APPROVALS

Approvals	CE, UL 61010-1
-----------	----------------

ADDITIONAL DATA

Weight	0.1 kg
--------	--------

Output connectors	Push-In
Output current per channel	Channel 1-4 :1, 2, 3, 4, 6, 8 A
Back-feeding loads	30 V DC
Cable size stranded max	2.5 mm ²
Clamp type	Push in
Input connector	Push-In
Input voltage dc max	30 V DC
Input voltage dc min	9.6 V DC
Life span	268 000 h 4x5 A 40 C

Material protection

Plastic

MTBF (IEC 61709)

1 142 000 h 4x5 A 40 C

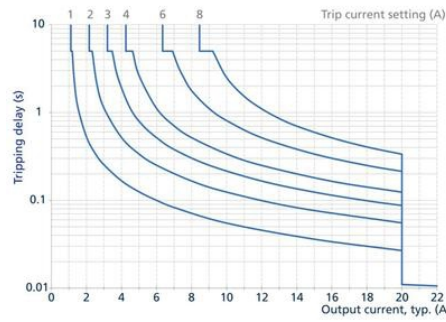

Fig. 6-2: Tripping delay depending on current slow tripping characteristic

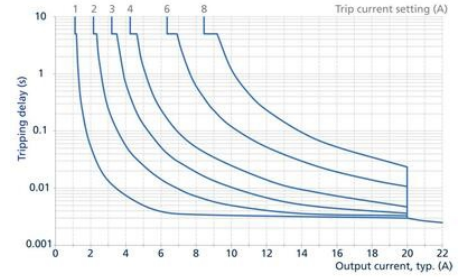

Fig. 6-1: Tripping delay depending on current fast tripping characteristic

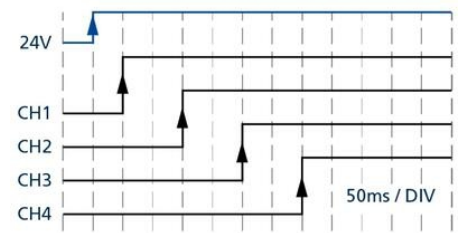
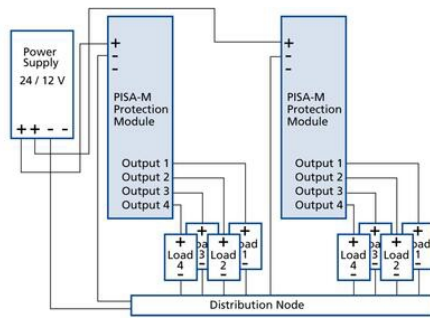
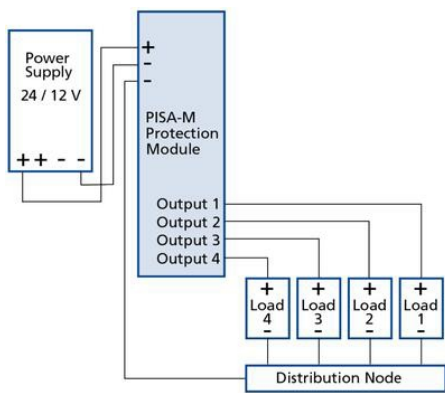

Fig. 14-1: Front side

A Input Terminals
Identical poles are internally connected.
(+) 1.1 Positive input pole
(-) 1.2, 1.3 Negative input pole

B Output Terminals
(+) 2.1 Channel 1 positive output pole
(-) 2.2 Channel 2 positive output pole
(+) 2.3 Channel 3 positive output pole
(-) 2.4 Channel 4 positive output pole

C Control Signal Input
(+) 3.1 Signal input positive pole
(-) 3.2 Signal input negative pole
Signal input can be used to send reset signal (1 s active) or for data communication using Digital Coded Interface.

D Status Signal Output
(+) 3.3 Signal output positive pole
(-) 3.4 Signal output negative pole
Signal output can be set to several operation modes.

E Channel Control Buttons
Press of single button to toggle selected output channel ON / OFF
Required duration of button press can be configured:
- Long press of single button to reset selected channel
- Press of button combinations to enter configuration modes
Note: See user manual for more information.

F Output Channel Status LEDs
- Green: Output channel ON
- Yellow: Output channel overload – prewarning before tripping channel
- Red: Output channel turned OFF (manually or remotely)
- Red (flashing): Output channel tripped due to overload of this channel
- Red (double-flashing): Output channel tripped due to device overload protection or power supply protection, see chapter 9 and 10
- LED OFF: Device is not powered
Note: For other blinking codes, see user manual

G QR code for direct access to documentation

5. Turn Output Channels ON or OFF

Each output channel can be switched ON and OFF individually.
The required duration of button press can be configured, see chapter 10 "Button Reaction Style".

- Output channel is ON → LED lights up green
- Output channel is OFF → LED lights up red

press any button

- Press the Channel Control Button (CCB) for the output channel to be modified depending on the selected button reaction style:
 - 50 ms in standard mode or
 - 1 s in long press mode
- The output channel will switch between ON and OFF.

6. Check Current Tripping Setpoint of Each Output Channel

Each LED indicates the current tripping setpoint for each output channel.
For example: LED 1 shows setting of output channel 1.

- The number of flashes indicates current setting in ampere.
For example: LED 1 flashes 4 x, set current tripping setpoint for output channel 1 is 4 A.
- The sequence will be shown two times.
- The device exits the checking mode and will return to regular operation.

- Press CCB1 and CCB4 simultaneously for 50 ms.
- Each LED will indicate the current tripping setpoint for each output channel by flashing green.
- Pressing any button during LED flashing stops the checking mode immediately.

12. Select Communication Mode

The device will exit setting mode automatically after 4 s inactivity.
The device is equipped with two signal ports. Status signal output (pin 3.1 – 3.2) and signal control input (pin 3.3 – 3.4).
These ports can be configured as follows:

Tripping Alarm:
Switch closes when at least one or more output channels are tripped.
- Status Signal Output ON → one or more output channels are tripped
- Status Signal Output OFF → no output channel tripped

Digital Coded Interface (DCI):
For more detailed information regarding DCI mode, please refer to the product datasheet.

Output Channel Off Alarm:
Switch closes when one or more channels are tripped or manually turned off.
- Status Signal Output ON → one or more output channels are tripped if turned off
- Status Signal Output OFF → all output channels are turned on

OK-Signal:
Switch closes if all output channels are turned on.
- Status Signal Output ON → all output channels are turned on
- Status Signal Output OFF → one or more output channels are tripped / turned off

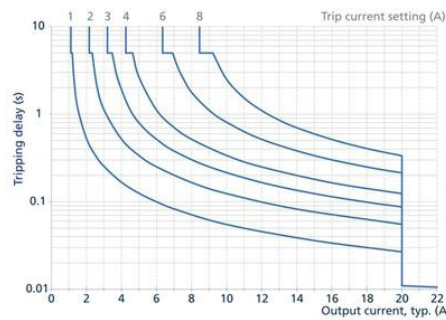
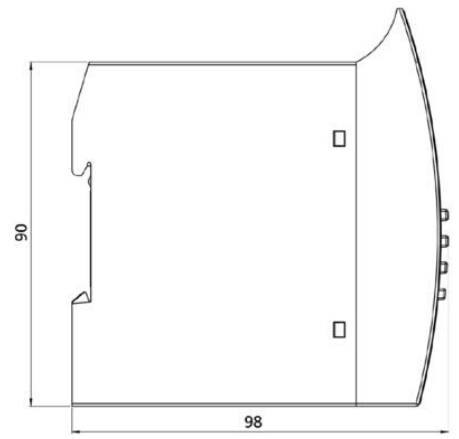
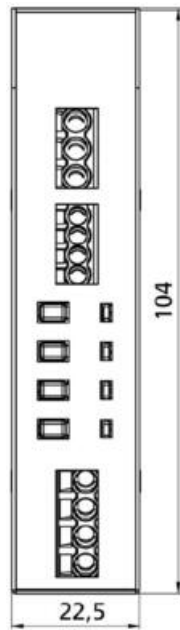

Fig. 6-2: Tripping delay depending on current slow tripping characteristic

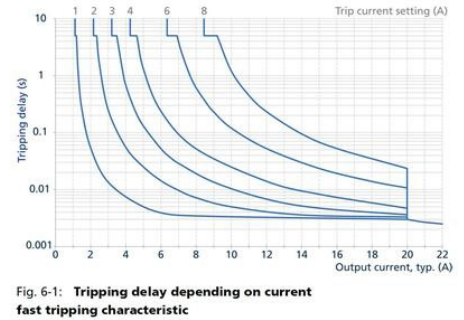

Fig. 6-1: Tripping delay depending on current fast tripping characteristic

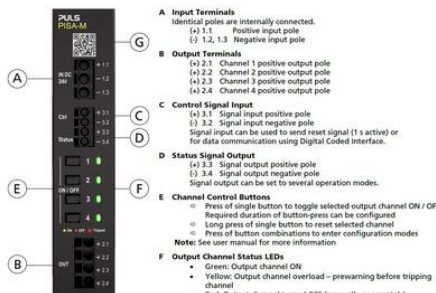
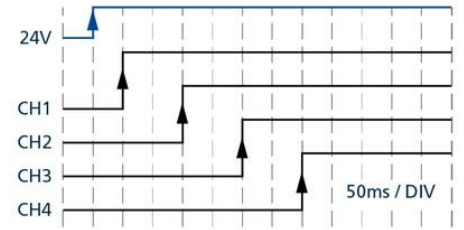
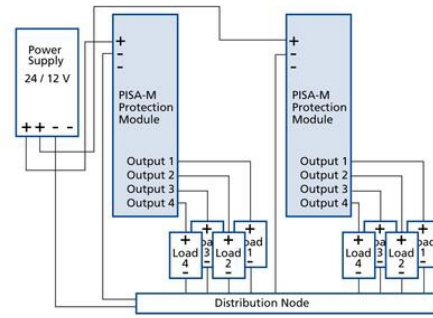
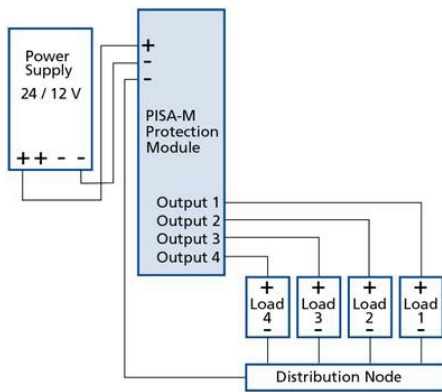

Fig. 14-1: Front side

- A Input Terminals**
Identical poles are internally connected.
(+) 1.1 Positive input pole
(-) 1.2, 1.3 Negative input pole
- B Output Terminals**
(+) 2.1 Channel 1 positive output pole
(+) 2.2 Channel 2 positive output pole
(+) 2.3 Channel 3 positive output pole
(+) 2.4 Channel 4 positive output pole
- C Control Signal Input**
(+) 3.1 Signal input positive pole
(-) 3.2 Signal input negative pole
Signal input can be used to send reset signal (1 s active) or for data communication using Digital Coded Interface.
- D Status Signal Output**
(+) 3.3 Signal output positive pole
(-) 3.4 Signal output negative pole
Signal output can be set to several operation modes.
- E Channel Control Buttons**
Press of single button to toggle selected output channel ON / OFF
Required duration of button press can be configured
Long press of single button to reset selected channel
Press of button combinations to enter configuration modes
Note: See user manual for more information
- F Output Channel Status LEDs**
Green: Output channel ON
Yellow: Output channel overload - prewarning before tripping channel
Red: Output channel turned OFF (manually or remotely)
Red (flashing): Output channel tripped due to overload of this channel
Red (double-flashing): Output channel tripped due to device overload protection or power supply protection, see chapter 9 and 10
LED OFF: Device is not powered
Note: For other blinking codes, see user manual
- G QR code for direct access to documentation**

5. Turn Output Channels ON or OFF

Each output channel can be switched ON and OFF individually. The required duration of button press can be configured, see chapter 10 "Button Reaction Style".

- Output channel is ON → LED lights up green
- Output channel is OFF → LED lights up red



- Press the Channel Control Button (CCB) for the output channel to be modified depending on the selected button reaction style:
 - 50 ms in standard mode or
 - 1 s in long press mode
- Pressing any button during LED flashing stops the checking mode immediately.

6. Check Current Tripping Setpoint of Each Output Channel

Each LED indicates the current tripping setpoint for each output channel. For example: LED 1 shows setting of output channel 1.

- The number of flashes indicates current setting in amperes. For example: LED 1 flashes 4 x, set current tripping setpoint for output channel 1 is 4 A.
- The sequence will be shown two times.
- The device exits the checking mode and will return to regular operation.



- Press CCB1 and CCB4 simultaneously for 50 ms.
- Each LED will indicate the current tripping setpoint for each output channel by flashing green.
- Pressing any button during LED flashing stops the checking mode immediately.

12. Select Communication Mode

- The device will exit setting mode automatically after 4 s inactivity.

The device is equipped with two signal ports. Signal status output (pin 3.1 - 3.2) and signal control input (pin 3.3 - 3.4). These ports can be configured as follows:

Tripping Alarm:

Switch closes when at least one or more output channels are tripped.

- Status Signal Output ON → one or more output channels are tripped
- Status Signal Output OFF → no output channel tripped

Digital Coded Interface (DCI):

For more detailed information regarding DCI mode, please refer to the product datasheet.

Output Channel Off Alarm:

Switch closes when one or more channels are tripped or manually turned off.

- Status Signal Output ON → one or more output channels are tripped if turned off
- Status Signal Output OFF → all output channels are turned on

OK Signal:

Switch closes if all output channels are turned on.

- Status Signal Output ON → all output channels are turned on
- Status Signal Output OFF → one or more output channels are tripped / turned off

