

DOGA 316 - DC WIPER MOTOR

Right angle worm gearbox

316.2711.20.00

Worm gearmotor 12 V dc, 2 Nm, 38 rpm, 3.4 A, shaft E22

- 12 - 24Vdc
- Up to 2Nm
- Up to 65rpm
- Compact low noise design
- High starting torque

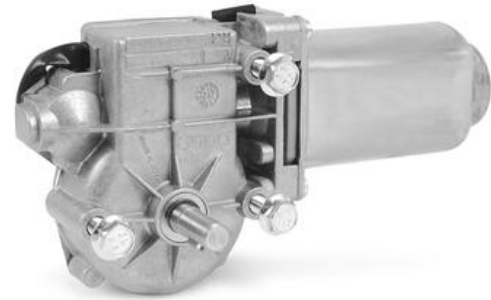

PRODUCT DESCRIPTION

The DOGA 316 series uses a brushed DC motor with worm gearbox and is developed to provide a compact, low noise and cost-effective solution to suit many industrial applications.

The standard hardened plastic worm wheel offers smooth, low noise operation and good performance, along with durability. IP10 is standard, with an EMC filter option.

VOLTAGE: 12 / 24Vdc supply - ideally suited to **battery powered** and **mobile applications**.

TORQUE: >2Nm nominal, >10Nm starting – a good choice for applications requiring **high start-up power**.

SPEED: 38 - 65rpm options using a range of motor/gearbox combinations.

For modest quantities DOGA can offer **product customisation** to better suit the individual needs of the customer and application. Adaptations can include changes to the output shaft, supply voltage, gear wheel material, cabling/connectors, gear ratios and motor windings.

Typical applications include:

Agriculture
Building access
Care aid
Medical
Office equipment
Marine
General industrial automation

TECHNICAL DATA

Current max	12 A
EMC filter	No
IP class	IP40

Max. torque	10
Nominal current	3.4 A
Nominal speed	38 rpm
Nominal torque	2
Positioning feedback	No
Ratio	62:1
Shaft diameter	9 mm
Supply voltage	12 V DC
Type of gearbox	Worm
Type of wheel	Plastic
Weight	0.9 kg

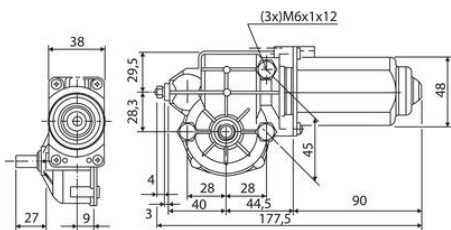
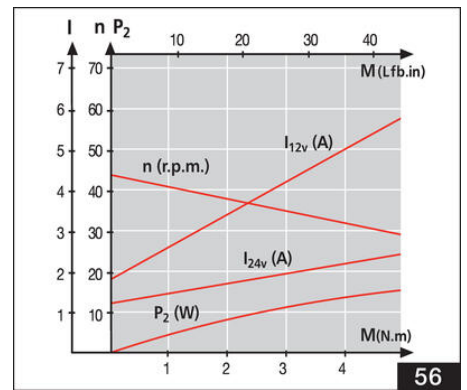
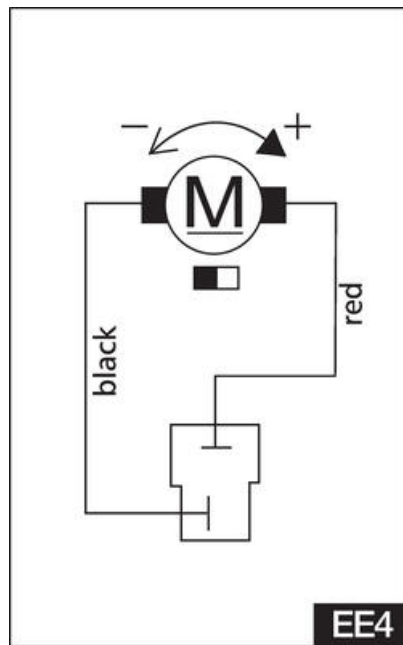
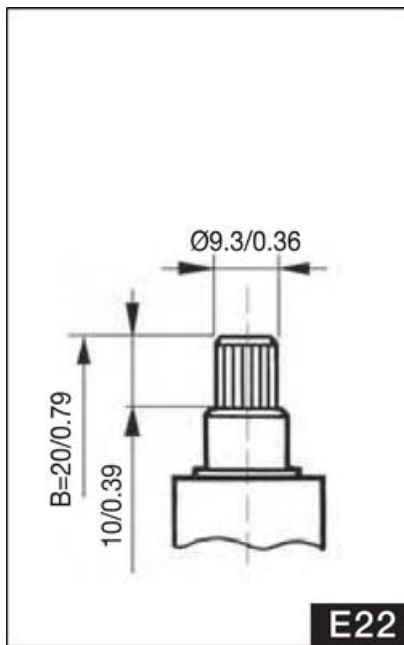

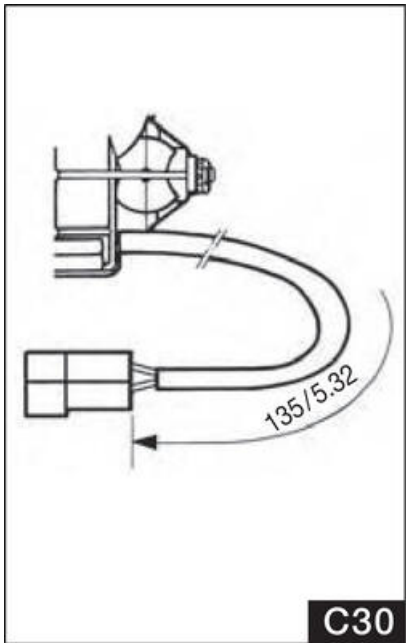

C30

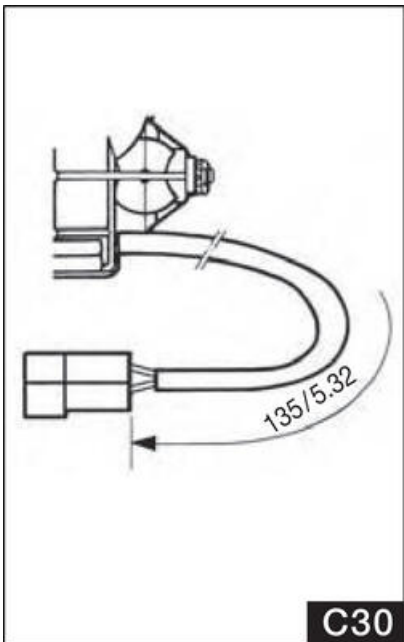
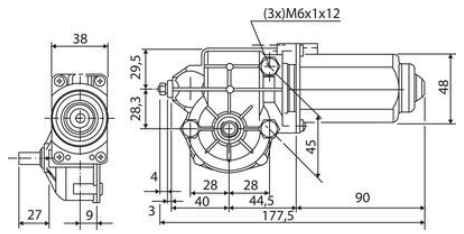

C30