

TAKEX - GN/DN MINIATURE PHOTOELECTRIC SENSORGNT10CR-PNP
PHOTOSENSOR MINI G T/BEAM PNP

- Miniature version with long distances
- Red visible light
- Cable or connector
- IP67

**PRODUCT DESCRIPTION**

The GN/DN series is a series of miniature photoelectric sensors with long distances. Modern technology has allowed for the successful manufacture of a range of low-price photoelectric sensors offering high technical performance. The compact housings, together with long distances, make this series appropriate for most applications.

TECHNICAL DATA

Approvals	CE
Distance min	0 mm
Electrical connection	Embedded 2m cable
Function	Dark on / Light on
IP class	IP67
Light type	Red LED
Light/dark switching	Yes
Output	PNP
Photocell technology	Transmitter / receiver
Power consumption max	0.022 A
Reaction time	0.5 ms
Sensing distance	10000 mm
Temperature operational max	55 °C
Temperature operational min	-25 °C

Voltage dc max	24 V
Voltage dc min	12 V

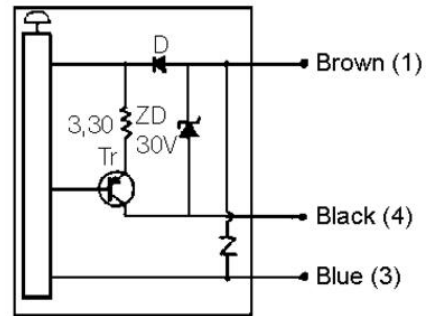
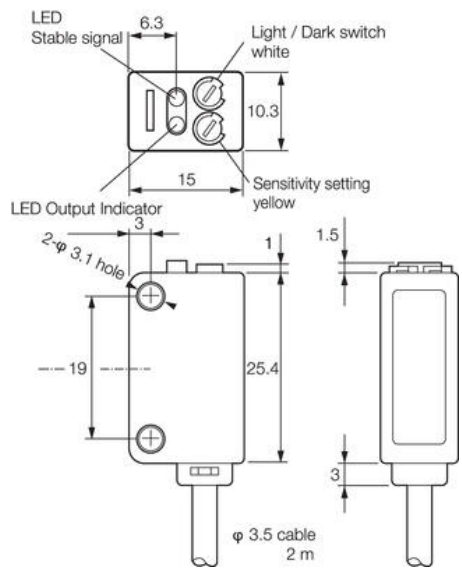
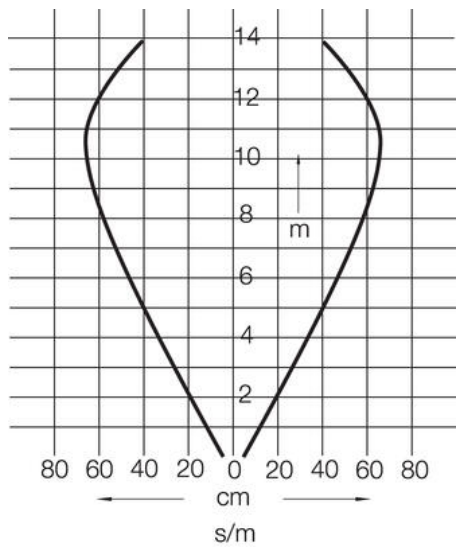

①Brown ②White ③Blue ④Black

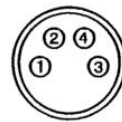
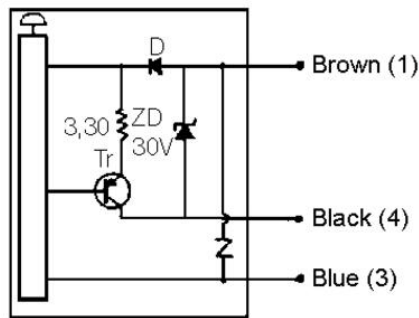

①Brown ②White ③Blue ④Black