

THK - LBR - TORQUE BALL BUSHING

LBR15

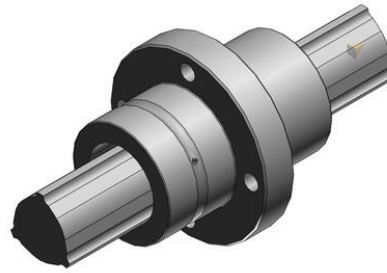

- Compactly torque ball bushing
- High torque capability
- High speed and quiet
- Long maintenance intervals



PRODUCT DESCRIPTION

Based on the type of heavy load model LBST, LBR is provided with flanged nut.
The spline shaft has three pairs of precision grooves, 120° between the bearings.

TECHNICAL DATA

Dynamic load	4.4 kN
Length	40 mm
Outer diameter	25 mm
Static load	8.4 kN