

## 3-WIRE INSTALLATION HYBRID TERMINALS - DLIS 2.5MM<sup>2</sup>

DLI, DLIS

1410.2  
DLIS 2.5 PE/L/NT, 2.5mm<sup>2</sup> installation terminal, PE, live,  
neutral, busbar

- Cross connectable
- Phase, Neutral and PE in one terminal
- 10 x 3 busbar connections
- Slide neutral disconnnet
- Colour coded

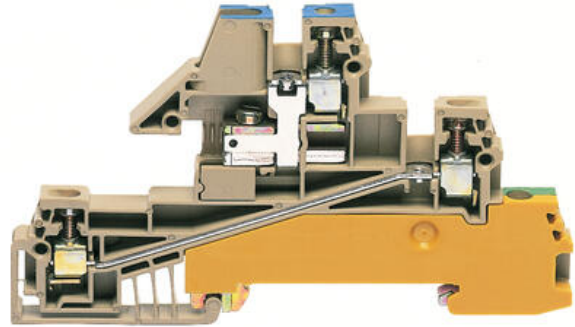

### PRODUCT DESCRIPTION

The DLI, DLIS range of installation terminals enable the ability to distribute power in a small footprint and gives the ability to disconnect the neutral connections.

To comply to VDE 100 (IEC 364) and VDE 0108, which stipulates the requirement that a circuit's association must be clearly detectable.

It is also required that an insulation test can be performed on each terminal without disconnecting the Neutral wire from the terminal blocks.

This is a specific requirement for public buildings such as hospitals, schools, airports, office buildings and institutions.

The terminals support the use of 10 x 3 busbar and is positioned on the outside of the terminals, the bar is held in place using the HP support plates. A sliding contact that contacts both sides of the busbar is used to connect and disconnect from the busbar.

This sliding contact permits functional testing independent of the operational mode.

## TECHNICAL DATA

### GENERAL DATA

Rated wire cross section	2.5 mm <sup>2</sup>
Colour	Beige
Rated voltage IEC	400 V
Rated current IEC	24 A
Mounting	TS 35
Rated impulse voltage	4 kV
Overvoltage category	III
Contamination degree	3

### DIMENSIONS

Length	90.5 mm
--------	---------

Width	6 mm
Height TS 35/7.5	53 mm

## CONNECTION DATA

Connections	4
Special connections	Busbar 10 x 3mm
Plug gauge acc. EN 60 947-1	A3
Cross connect channels	2
Cross section single wire from	0.2 mm <sup>2</sup>
Cross section single wire to	4 mm <sup>2</sup>
Cross section stranded wire from	0.2 mm <sup>2</sup>
Cross section stranded wire to	4 mm <sup>2</sup>
Cross section stranded with ferrule from	0.2 mm <sup>2</sup>
Cross section stranded with ferrule to	2.5 mm <sup>2</sup>
Rated wire cross section from (AWG)	22
Rated wire cross section to (AWG)	14
Stripping length	8 mm
Screw size	M 2,5
Screw type	Slotted
Torque min	0.4
Torque max	0.8

## MATERIALS

Insulation material	Polyamide 6.6
Flammability class	UL94-V2
Operating temperature from	-40 °C
Operating temperature to	105 °C

## ADDITIONAL DATA

Tariff code	85369010
Country of origin	CZ
Weight	26.8 g
Pack size	50
Type of terminal	Screw Terminals, DIN Rail terminals

