

LCD HOURS RUN METER, CODIX 141/143

6.141.012.300

HOURLY COUNTER 141 10-30VDC PNP/NPN

- 10-30 V dc
- 99999.99h
- 7 Digit display
- PNP/NPN input



PRODUCT DESCRIPTION

Timer Codix 141 is run on a 10-30 V DC supply voltage. Able to work with both PNP and NPN inputs. Memory function supplied as standard. The reset button at the front of the counter can be locked. The startup time is 500 ms. If the voltage falls below 8 V, a warning message is displayed and the data is saved. The counter comes with clamps, gaskets and separate front frames to fit 22 x 45 mm panel holes.

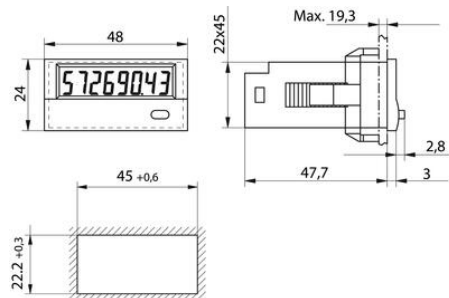
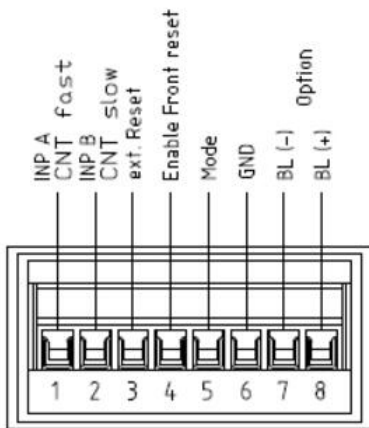

Frontram följer med räknaren

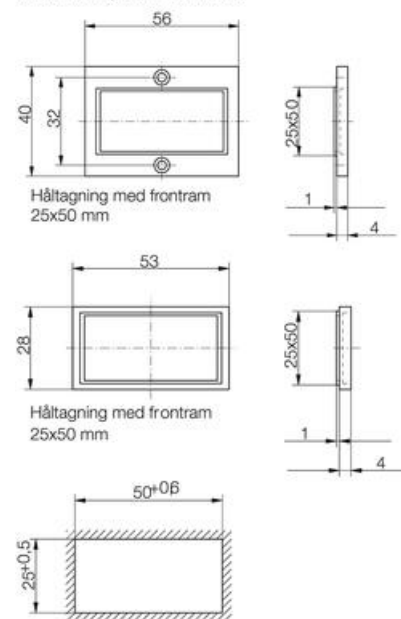

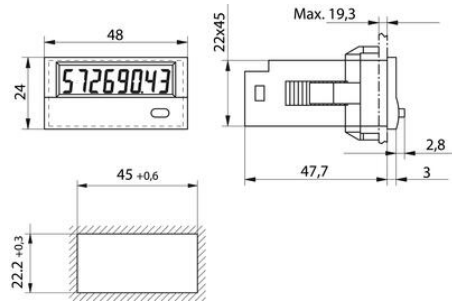
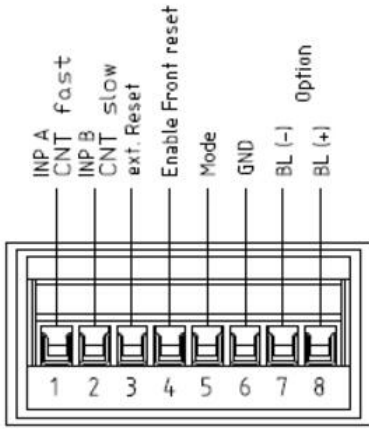

Frontram följer med räknaren

